

**TW2018U-80W-40
COMPACT DUPLEX VARIABLE SPEED
BOOSTER PUMP SYSTEM**

The **TW2018U-80W-40 Duplex Booster Pump System** is equipped with centrifugal pumps regulated by variable frequency drives that control the pump to maintain constant pressure regardless of varying demand or fluctuating incoming pressure.

System is built to fit through a 30" doorway.

VFD drives will **ALTERNATE** lead pump every 24 hours of run time. Second pump will remain on standby.

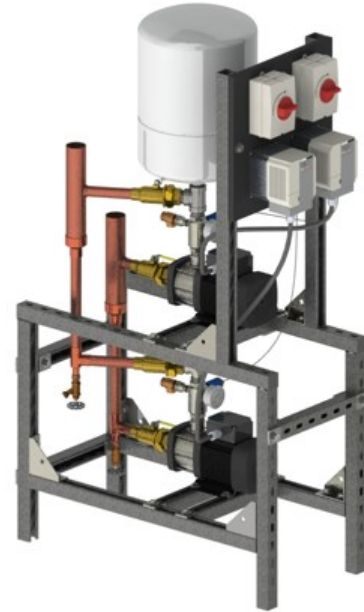

*All parts shown included
Actual system components may vary
Some assembly required*

Lead-Free (Wetted) components:

- Pumps: Cast Iron or SS Option (upgrade)
- Relief valves: LF Brass
- Pressure Gauges: LF Brass
- Transducers: Stainless Steel
- Check valves: LF Brass
- Ball Valves: LF Brass
- Manifolds: Type L Copper
- Fittings: LF Brass or SS

* All lead-free brass shall contain <.25% Pb

Technical Specifications:

- Pumps:** Walrus [8T-3K]
- Horse Power:** 1-1/2 HP per pump
- VF Drives:** Yaskawa
- Flow Rate:** 80 GPM (40 GPM per pump)
- Boost:** 40 PSI
- Set Pressure:** 65 PSI (unless otherwise specified)
- Manifolds:** 2 Inch
- Tank:** 8.5 Gallon (PLT-20)
- Frame:** 16" W X 58" H X 34" D
- Power options:** Two Independent circuits required
208-220V/1PH
208-220V/3PH
360-480V/3PH
Specify when ordering

Performance curve for each pump

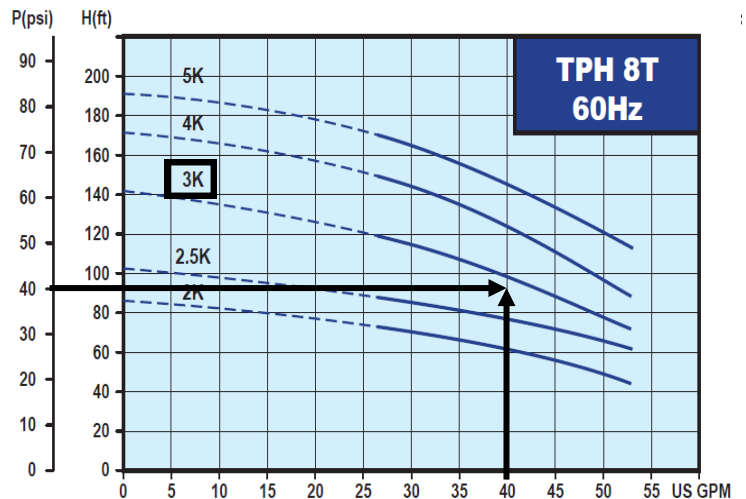

SYSTEM CONFIGURATION

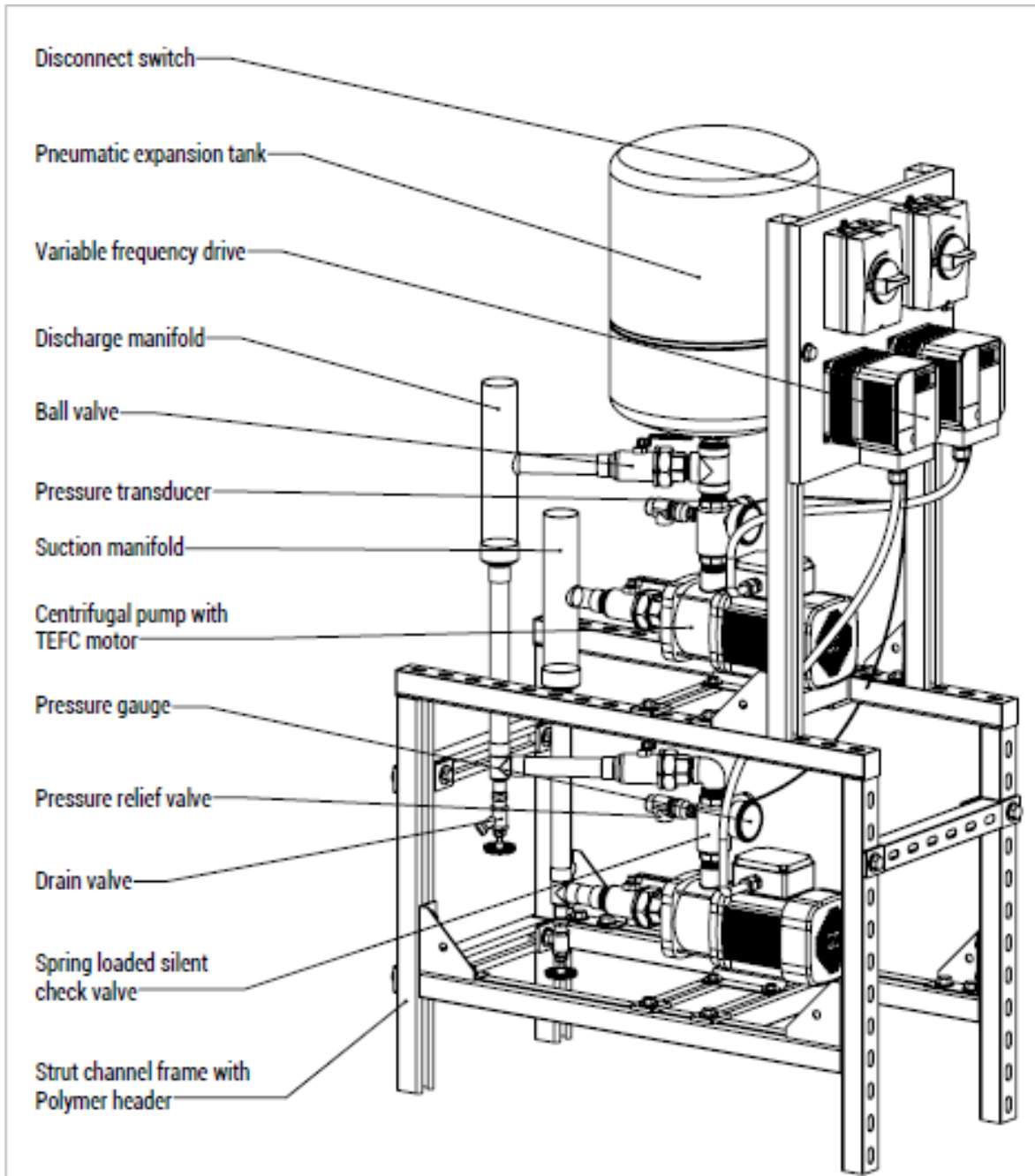

PROPRIETARY AND CONFIDENTIAL
THE INFORMATION CONTAINED IN THIS DRAWING IS THE SOLE PROPERTY OF TOWLE WHITNEY LLC. ANY REPRODUCTION IN PART OR AS A WHOLE WITHOUT THE WRITTEN PERMISSION OF TOWLE WHITNEY LLC IS PROHIBITED.

DIMENSIONS ARE SUBJECT TO CHANGE. DO NOT USE FOR CONSTRUCTION UNLESS OTHERWISE SPECIFIED. DIMENSIONS ARE IN INCHES.

DO NOT SCALE DRAWING

	NAME	DATE
DRAWN	VID	4/25/23
CHECKED	DW	4/25/23
COMMENTS:		

TOWLE WHITNEY LLC	
Duplex Over Under Variable Speed Booster System	
SIZE	DWG. NO.
A	2023-04-25-A
SCALE 1/4"	REV. SHEET 1 OF 1

SYSTEM DIMENSIONS

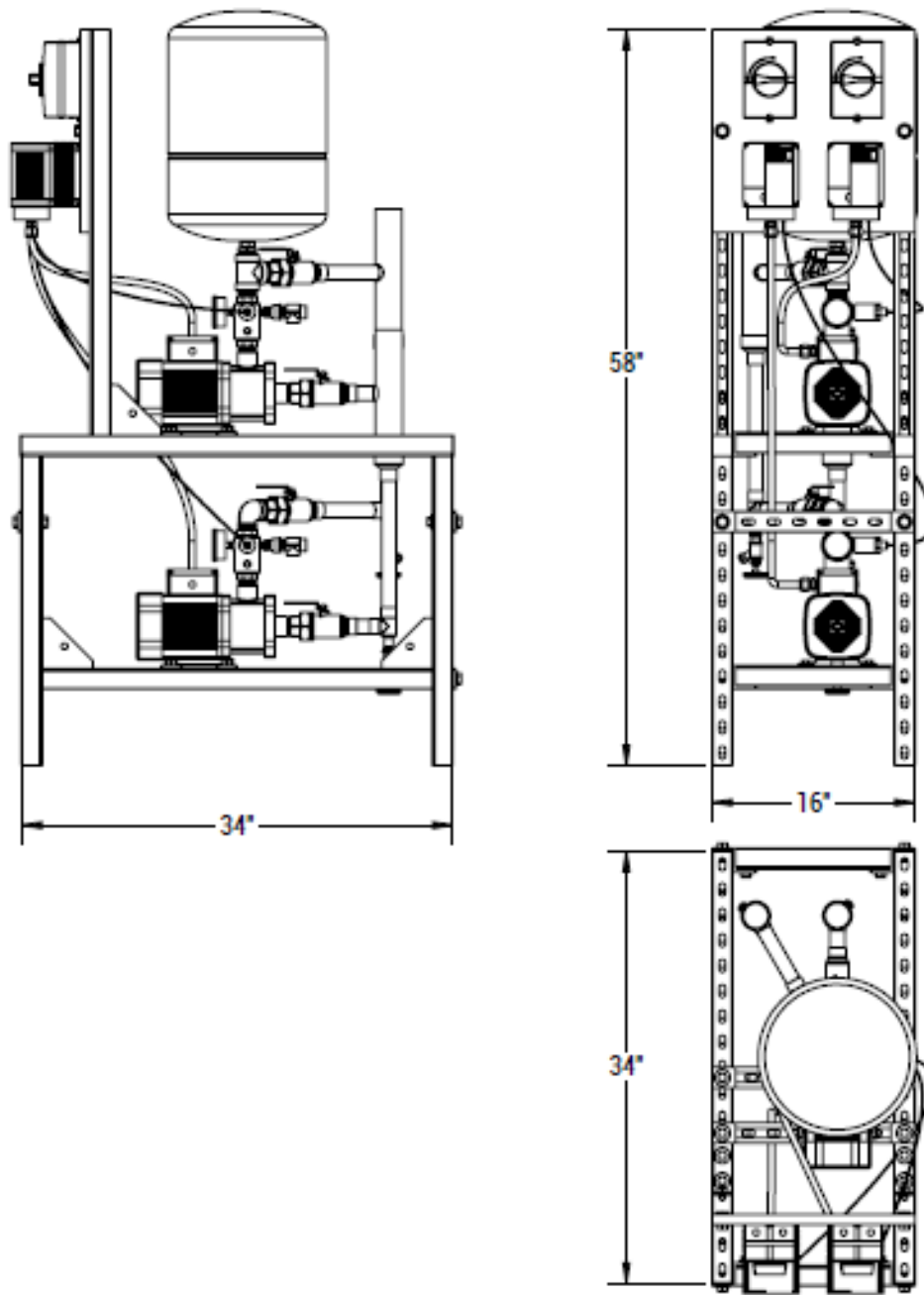

PROPRIETARY AND CONFIDENTIAL
THE INFORMATION CONTAINED IN THIS DRAWING IS THE SOLE PROPERTY OF TOWLE WHITNEY LLC. ANY REPRODUCTION IN PART OR AS A WHOLE WITHOUT THE WRITTEN PERMISSION OF TOWLE WHITNEY LLC IS PROHIBITED.

DIMENSIONS ARE SUBJECT TO CHANGE
DO NOT USE FOR CONSTRUCTION
UNLESS OTHERWISE SPECIFIED
DIMENSIONS ARE IN INCHES

DO NOT SCALE DRAWING

DRAWN	VID	DATE	4/25/23
CHECKED	DW	DATE	4/25/23
COMMENTS:			

TOWLE WHITNEY LLC	
Duplex Over Under Variable Speed Booster System	
SIZE	DRWG. NO. 2023-04-25-B
A	REV.
SCALE: 1/16	WEIGHT:
SHEET 1 OF 1	

Assembled Units:

- All “wetted surfaces” shall be lead free (<.25% Pb) in conformance with the 1/4/14 federal law
- Shall include a separate and independent variable frequency drive (VFD) for each pump with a pressure transducer, pressure gauge, and relief valve. Piping and frame shall not interfere with access to the controls
- Each pump shall include isolation valves on both the suction and discharge piping
- Each pump shall have a separate and independent disconnect box
- Shall be mounted on a frame for ease of transport and installation.

Variable frequency drive:

- Will ALTERNATE the lead pump every 24 hours (field adjustable) of run time. The lag pump shall be in standby
- Shall have hands-off automatic (HOA) capability
- Rated to operate using specified power requirement. The drive efficiency shall be 98% or better
- Have UL approval with all factory installed options and preset values and/or last saved data values will remain available to the operator after power outage
- Shall have at least NEMA 1 rated conduit enclosure
- The program will protect the pumps against damaging hydraulic conditions such as:
 - Motor overload, Pump overflow surges, Loss of prime due to incoming water supply interruption, Hunting
 - Protection from overload through frequency/current optimization
 - Protection from hydraulic damage by restricting the pumps to operate beyond their published end of curve
- Shall have the ability to automatically restart after an over-current, over-voltage, under-voltage or loss of input signal
- Shall have an operator control panel [keypad] for customization of parameters
- Shall include a feature to upload/download parameters into an external device to be used with another drive or the same drive
- Shall have a removable non-volatile memory device
- Shall be capable of accepting individual analog inputs from transducer. All transducer inputs must be wired to the variable frequency drive for continuous scan and comparison function
- Ladder logic program shall utilize a proportional - integral - derivative control function
- Shall display the following values:
 - Pump running/standby, Pump speed in Hz, User adjustable parameters such as PID set points, Motor frequency, Motor current, Threshold set points for PID error, Min operating frequency, Troubleshooting and diagnostics of faults

Transducer:

- The transducer shall be rated for required system pressure and shall be 4-20 mA analog
- Separate transducers shall be supplied for each variable frequency drive to ensure redundancy

Centrifugal pump:

- Shall have a cast iron casing with 304 stainless steel impellers. (All Stainless Steel pumps are an available upgrade)
- Shall have a 316 stainless steel shaft sleeve. Mechanical seal shall be rated to withstand pressure of up to 142 PSI
- Motor shall be to totally enclosed fan cooled (TEFC). and manufactured in compliance with CE, RoHS and CSA

Pneumatic expansion tank:

- Pneumatic expansion tank shall be rated for use with potable water with an operating pressure of a maximum 125 PSI
- Pre-charged to a pressure of 10 PSI below system operating pressure for system to run properly

Manifolds, valves and fittings:



- Manifolds are designed for either right or left access
- Shall be sized appropriately to allow water velocity not exceeding 10 ft/sec, to minimize cavitation and turbulence
- Check valves shall be silent and spring-loaded

Installation:



- Equipment shall be installed in accordance with applicable local building, electrical and plumbing codes
- Shall be installed indoors (unless otherwise specified) and protected from water spray

COMPONENT COMPLIANCE

Electrical

Yaskawa VFD	UL 508C Power Conversion CSA 22.2 Industrial Controls		CE	RoHS
Lovato Shut-off	NEMA4		CE	RoHS

Pumps

Grundfos CM(I) SS Series	NSF 61		CE	
Grundfos CR(I) SS Series	NSF 61		CE	
Goulds 125MS Series	NSF 61		CE	
Goulds BF Series	NSF 61		CE	
Walrus TPH Series	NSF 372		CE	RoHS

Plumbing

Bluefin BVT200 Ball Valves	NSF 61			
Webstone BVT200 Ball Valves	NSF 61			
Bonomi Check 1000012	NSF 61		CE	
Flomatic VFD Check	NSF 61			
Victaulic 607 "E" Coupling	NSF 61			
Victaulic 660 Cap	NSF 61			
Amtrol PL Tank	NSF 61			
Watts PLT Tank	NSF 61			
Manifolds / piping	Type L Copper			
Fittings	Copper			
Discharge Riser	Copper		CE	
- Pressure Relief valve:				
- SS 4-20mA Transducer:				
- Pressure Gauges:	CA AB1953			

Sealants

Rectorseal Nokorode Flux	NSF 61
Worthington SILVER Solder	NSF 61
LocTite 567 Thread Sealant	NSF 61
Gasola Thread Sealant	NSF 61



Warranty: Provide VFD warranty, for one year from startup, not to exceed 18 months from the date of shipment. Warranty shall include parts, and labor allowance for repair hours.



Performance Features (Drive)

- Ratings:
1 to 5 HP at 200-240 VAC 1-Ph.
1 to 25 HP (ND) at 200-240 VAC 3-Ph.
1 to 25 HP (ND) at 380-480 VAC 3-Ph.
- Overload Capacity:
120% for 60 sec. (Normal Duty)
- Control Methods: V/f Control,
Open Loop Current Vector Control
- DC injection braking, ramp to stop
- Electronic reversing
- Adjustable accel/decel: 0.01 to 6000 seconds
- Controlled speed range:
40:1⁽¹⁾ 100:1⁽²⁾
- Speed Regulation:
± 0.5 to 1% with slip compensation⁽¹⁾
± 0.2%⁽²⁾
- Displacement power factor: 0.98
- Output frequency: 0 to 400 Hz
- Frequency resolution:
0.01 Hz with digital reference
0.06 / 60 Hz with analog reference
- Frequency accuracy:
0.01% with digital command
0.5% with analog command
- Volts / hertz ratio: infinitely adjustable pattern
- DC Injection braking: adjustable amplitude, duration, current limited
- Torque boost: full range, auto
- Power loss ride-thru: 0.5 sec.
- Speed search
- Auto restart
- 3 Critical frequency rejection settings
- Slip Compensation
- Energy Savings Function
- Enhanced PID with loss of feedback function

⁽¹⁾ V/f Mode

⁽²⁾ Open Loop Current Vector Mode

Design Features (Drive)

- Dual microprocessor logic
- Digital keypad operator, 5 digits
- LED status display
- Remote Mount Keypad Capability
- RJ-45 Style Digital Operator Connector
- 7 multifunction digital inputs
- 3 multifunction digital outputs
- Hardwire baseblock (EN954-1 Cat. 3)
- Programmable form C output contact for customer use: 1A at 250 VAC or 30 VDC
- 24 VDC control logic compatible with sourcing or sinking outputs (PNP or NPN)
- Carrier frequency: 15 kHz max; swing PWM
- 2 Remote speed references:
0-10 VDC (20 kohms) or isolated 4-20 mA (250 ohms)
- Signal follower: bias and gain
- 2 programmable open collector outputs
- Analog monitor output:
0-10 VDC proportional to output frequency or output current
- Approx. 400 parameters and monitors
- Digital pulse train input (33 kHz max.)
- Cooling fan controlled by drive run/stop
- RS-422/485 Modbus 115 kbps
- UL recognized electronic overload
- MTBF: 28 years
- NEMA 1 enclosure
- Side-by-Side mounting
- Maintenance monitors

Protective Features (Drive)

- Current limit, stall prevention during accel, decel, and run
- Motor and drive overload
- Over voltage prevention function
- Instantaneous over current
- Short circuit
- Under voltage
- Heatsink overheat
- Ground fault protection
- Over/under torque
- Short circuit current rating: 30kA rms sym.

Pump Control Features

- Operator keypad with intuitive pump language
- Hand-Off-Auto
- Programmable pump process set point
- Pump start level and start time
- Sleep protection
- Simplex, duplex and triplex control
- Automatic system restart
- No flow detection
- Low and high feedback set points
- Pre-charge low level control
- Thrust bearing control
- Automatic system stabilization
- Motor condensation pre-heat function

Pump Protective Features

- Dry well
- Air in system
- Blocked impeller
- Pump over cycling
- No flow protection
- Loss of prime
- Transducer loss
- Over torque

Pump Alarms and Messages

- Low feedback
- High feedback
- Low level
- Low water
- Pump over cycling
- No flow detection
- Loss of prime
- Pump fault
- Motor thermostat
- Pre-charge mode
- Thrust bearing active
- Start mode active
- Sleep mode active

MULTISTAGE CENTRIFUGAL PUMP

WALRUS

MULTISTAGE CENTRIFUGAL PUMP

TPH2T/4T/8T/12T

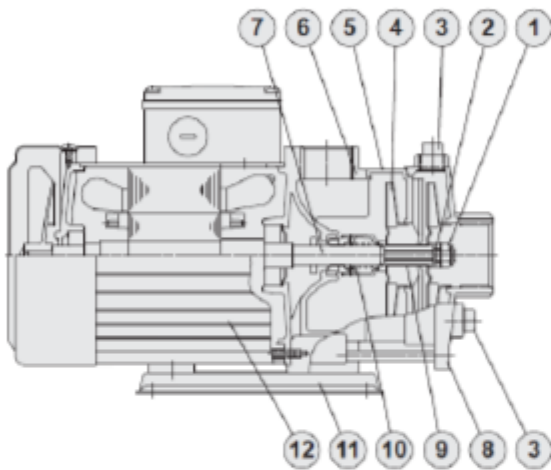

Motors:

- The pump is coupled with (TEFC) Totally Enclosed Fan Cooled, squirrel-cage motor.
- Nominal speed: 3500 rpm at 60Hz
- Protection class: IP54
- Insulation class: F

Pumps:

- Horizontal multi-stage centrifugal pump
- Non self-priming
- close coupled design
- Impellers mounted on extended motor shaft.

Materials

No.	Part name	Material		
		Standard	S series	N series
1	Lock Nut	SUS 316	SUS 316	SUS 316
2	Sleeve(Shaft End)	SUS 304	SUS 304	SUS 316
3	Water Plug	FC 20	SUS 304	SUS 316
4	Impeller	SUS 304	SUS 304	SUS 316
5	Intermediate Chamber	SUS 304	SUS 304	SUS 316
6	Pump Casing	FC 20	SUS 304	SUS 316
7	Shaft	SUS 304	SUS 304	SUS 316
8	Suction Chamber	FC 20	SUS 304	SUS 316
9	Sleeve	SUS 304	SUS 304	SUS 316
10	Mechanical Seal	Tungsten carbide + HNBR		
11	Mounted Base	Coating Steel	SUS 316	
12	Motor Shell	Aluminum alloy		

SUS 304 may be replaced by SUS316 depended on stock availability.

Operating Limits:

- Ambient temperature: Max. 104°F (40°C)
- Liquid temperature range: 32°F (0°C) to 194°F (90°C)
- Operating pressure: Max. 142 psi
- Inlet pressure: Max 85 psi

Suitable Liquids:

- Clean or other non-corrosive liquids



Models: PLT-5, PLT-12, PLT-20

Air Side Pre-pressure (psi) (bar)	Water Side Volume at 150psi (10.3 bar) (gallons)		
	PLT-5	PLT-12	PLT-20
20 (1.4)	1.48	3.42	7.102
40 (2.8)	1.26	2.88	5.882
60 (4.1)	1.0	2.49	4.705
80 (5.5)	.80	1.85	4.009

Description	PLT-5 Order No. 0067370	PLT-12 Order No. 0067371	PLT-20 Order No. 0067372
Max. Pressure - psi	150	150	150
Max. Temp. - °F	200	200	200
Tank Volume - gal.	2.1	4.5	8.5
Tank Acceptance - gal.	1.26	2.8	3.4
Air Pre-charge - psi	20	20	20
Connections Size - in.	¾ male	¾ male	¾ male
Diameter - in.	8	10.5	12½
Length - in.	11	13.5	19¾
Weight - lbs.	5.5	10	15



Certified to ANSI/NSF 61
(73°F/23°C)



Listed by IAPMO

CALIFORNIA PROPOSITION 65 WARNING
WARNING: This product contains chemicals known to the State of California to cause cancer and birth defects or other reproductive harm. (California law requires this warning to be given to customers in the State of California.)
For more information: www.watts.com/prop65

Disclaimer: The manufacturer of this tank does not accept any liability or other responsibility for personal injury or property damage resulting from improper use, installation or operation of this tank or the system of which it is a part.

Notice: The expansion tank, piping and your connections may in time leak. Select a location to install the expansion tank where a water leak will not damage the surrounding area. The manufacturer is not responsible for any water damage in connection with this expansion tank.

Limited Warranty: Watts Regulator Co. (the "Company") warrants each product to be free from defects in material and workmanship under normal usage for a period of one year from the date of original shipment. In the event of such defects within the warranty period, the Company will, at its option, replace or recondition the product without charge.

THE WARRANTY SET FORTH HEREIN IS GIVEN EXPRESSLY AND IS THE ONLY WARRANTY GIVEN BY THE COMPANY WITH RESPECT TO THE PRODUCT. THE COMPANY MAKES NO OTHER WARRANTIES, EXPRESS OR IMPLIED. THE COMPANY HEREBY SPECIFICALLY DISCLAIMS ALL OTHER WARRANTIES, EXPRESS OR IMPLIED, INCLUDING BUT NOT LIMITED TO THE IMPLIED WARRANTIES OF MERCHANTABILITY AND FITNESS FOR A PARTICULAR PURPOSE.

The remedy described in the first paragraph of this warranty shall constitute the sole and exclusive remedy for breach of warranty, and the Company shall not be responsible for any incidental, special or consequential damages, including without limitation, lost profits or the cost of repairing or replacing other property which is damaged if this product does not work properly, other costs resulting from labor charges, delays, vandalism, negligence, fouling caused by foreign material, damage from adverse water conditions, chemical, or any other circumstances over which the Company has no control. This warranty shall be invalidated by any abuse, misuse, misapplication, improper installation or improper maintenance or alteration of the product.

Some States do not allow limitations on how long an implied warranty lasts, and some States do not allow the exclusion or limitation of incidental or consequential damages. Therefore the above limitations may not apply to you. This Limited Warranty gives you specific legal rights, and you may have other rights that vary from State to State. You should consult applicable state laws to determine your rights. **SO FAR AS IS CONSISTENT WITH APPLICABLE STATE LAW, ANY IMPLIED WARRANTIES THAT MAY NOT BE DISCLAIMED, INCLUDING THE IMPLIED WARRANTIES OF MERCHANTABILITY AND FITNESS FOR A PARTICULAR PURPOSE, ARE LIMITED IN DURATION TO ONE YEAR FROM THE DATE OF ORIGINAL SHIPMENT.**





Booster Pump Systems

Three Year Limited Warranty

This warranty applies to booster pump systems built by Towle Whitney LLC, and shall:

- Exist 36 months from the date of shipment.
- Be in effect only after installation photographs are received by Towle Whitney LLC.

Towle Whitney LLC liability under this warranty shall be limited to the repair or replacement of any part or parts found to be defective (material or workmanship) within the warranty period. Towle Whitney LLC shall determine whether the part needs to be returned, or field scrapped. The warranty excludes:

- Any water damage or consequential damage.
- Transducers & Pump Seals.
- Debris in water causing damage to pump internal parts.
- Systems not installed in accordance with Installation and Maintenance Instructions.
- Labor, transportation, and related costs incurred by the customer.
- Misuse, negligence, inappropriate chemicals or additives in water.
- Inadequate protection from freezing.
- Lightning, high voltage spikes, accidents, floods, or acts of God.
- Re-Installation costs of repaired or replacement equipment.
- Re-Imbursement for the loss caused by interruption of service.
- Adjusting drive parameters without consulting Towle Whitney.

This warranty applies to all states and territories of the United States and Canada only. There are no express or implied warranties, including merchantability or fitness for a particular purpose, which extend beyond those warranties described or referred to above.

Some jurisdictions do not allow the exclusion or limitation of incidental or consequential damages and some jurisdictions do not allow limit actions on how long implied warranties may last. Therefore, the above limitations or exclusions may not apply. This warranty gives you specific legal rights and you may also have other rights which vary from jurisdiction to jurisdiction.