



**TW3018T-210R-40  
TRIPLEX VARIABLE SPEED  
BOOSTER PUMP SYSTEM**

**TW3018T-210R-40 DUPLEX**

The *TW3018T-210R-40 Triplex Booster Pump System* is equipped with centrifugal pumps regulated by variable frequency drives that control the pump to maintain constant pressure regardless of varying demand or fluctuating incoming pressure.

VFD drives will ALTERNATE lead pump every 24 hours of run time. Second and third pump will remain on standby.



*All parts shown included  
Actual system components may vary  
Some assembly required*

**Lead-Free (Wetted) components:**

- Pumps: Stainless Steel
- Relief valves: LF Brass
- Pressure Gauges: LF Brass
- Transducers: Stainless Steel
- Check valves: LF Brass
- Ball Valves: LF Brass
- Manifolds: Type L Copper
- Fittings: LF Brass or SS

\* All lead-free brass shall contain <.25% Pb

**Technical Specifications:**

- Pumps:** Grundfos [CM10-2]
- Horse Power:** 3.4 HP per pump
- VF Drives:** Yaskawa
- Flow Rate:** 210 GPM (70 GPM per pump)
- Boost:** 40 PSI
- Set Pressure:** 65 PSI (unless otherwise specified)
- Manifolds:** 3 Inch
- Tank:** 26 Gallon non-ASME
- Frame:** 43"W X 43"H X 34"D
- Power options:** Three Independent circuits required  
208-220V/1PH  
208-220V/3PH  
360-480V/3PH  
*Specify when ordering*

*Performance curve for each pump*

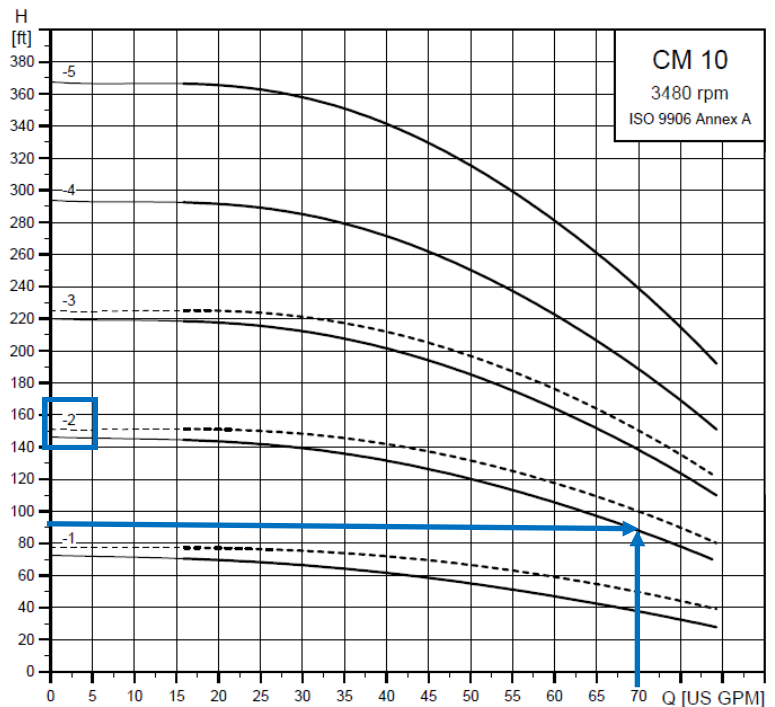

**SYSTEM CONFIGURATION**

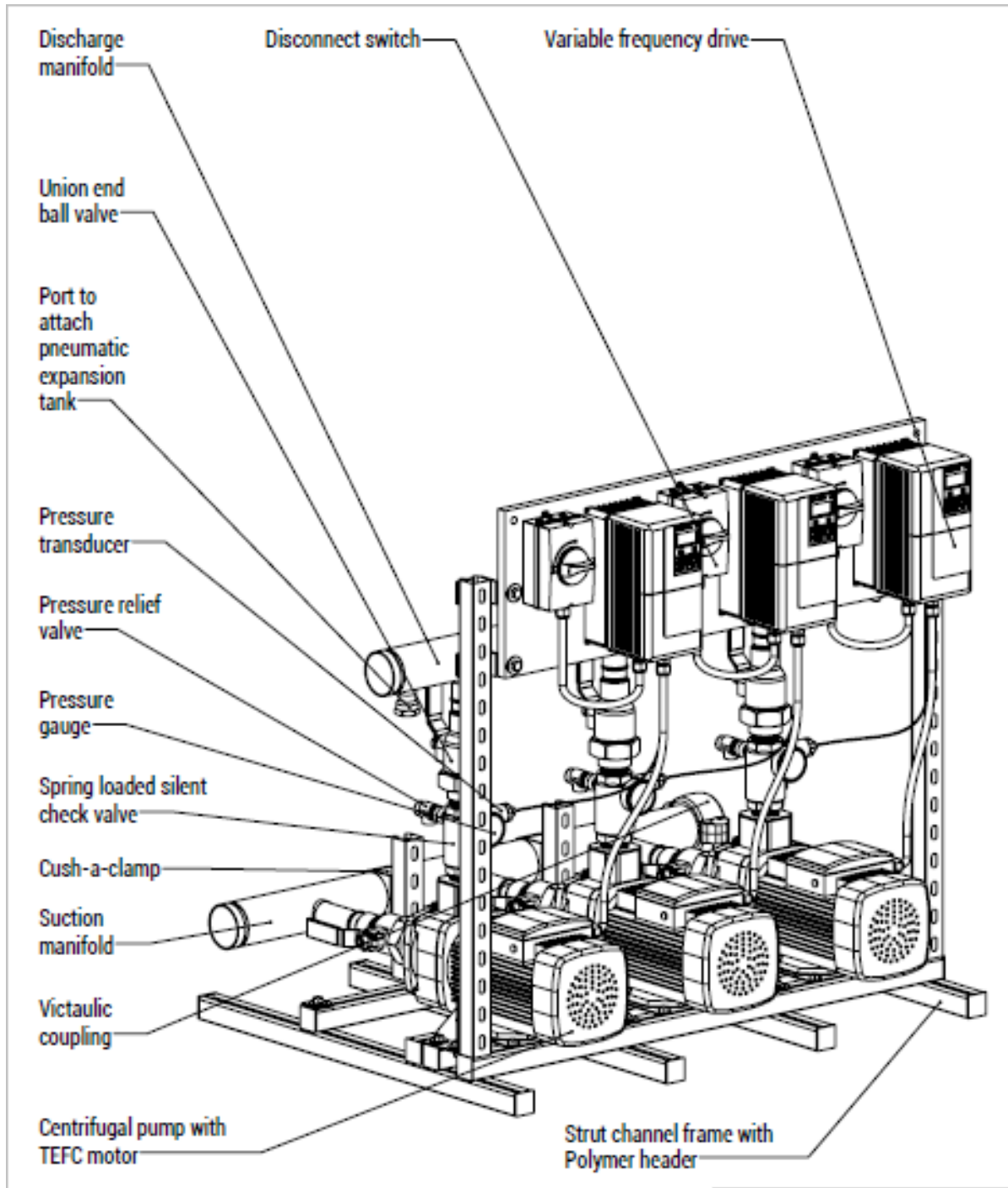

<p><b>PROPRIETARY AND CONFIDENTIAL</b> THE INFORMATION CONTAINED IN THIS DRAWING IS THE SOLE PROPERTY OF TOWLE WHITNEY LLC. ANY REPRODUCTION IN PART OR AS A WHOLE WITHOUT THE WRITTEN PERMISSION OF TOWLE WHITNEY LLC IS PROHIBITED.</p>		<p>DIMENSIONS ARE SUBJECT TO CHANGE DO NOT USE FOR CONSTRUCTION UNLESS OTHERWISE SPECIFIED DIMENSIONS ARE IN INCHES</p>		<p><b>TOWLE WHITNEY LLC</b></p>	
		<p>DO NOT SCALE DRAWING</p>		<p><b>Triplex Variable Speed Booster System</b></p>	
		<p>DATE 10/12/22</p>	<p>DATE 10/12/22</p>	<p>DRWG. NO. 2022-10-12-A</p>	
		<p>SCALE: 1/2" = 1'-0"</p>		<p>WEIGHT: _____</p>	
				<p>SHEET 1 OF 1</p>	

**SYSTEM DIMENSIONS**

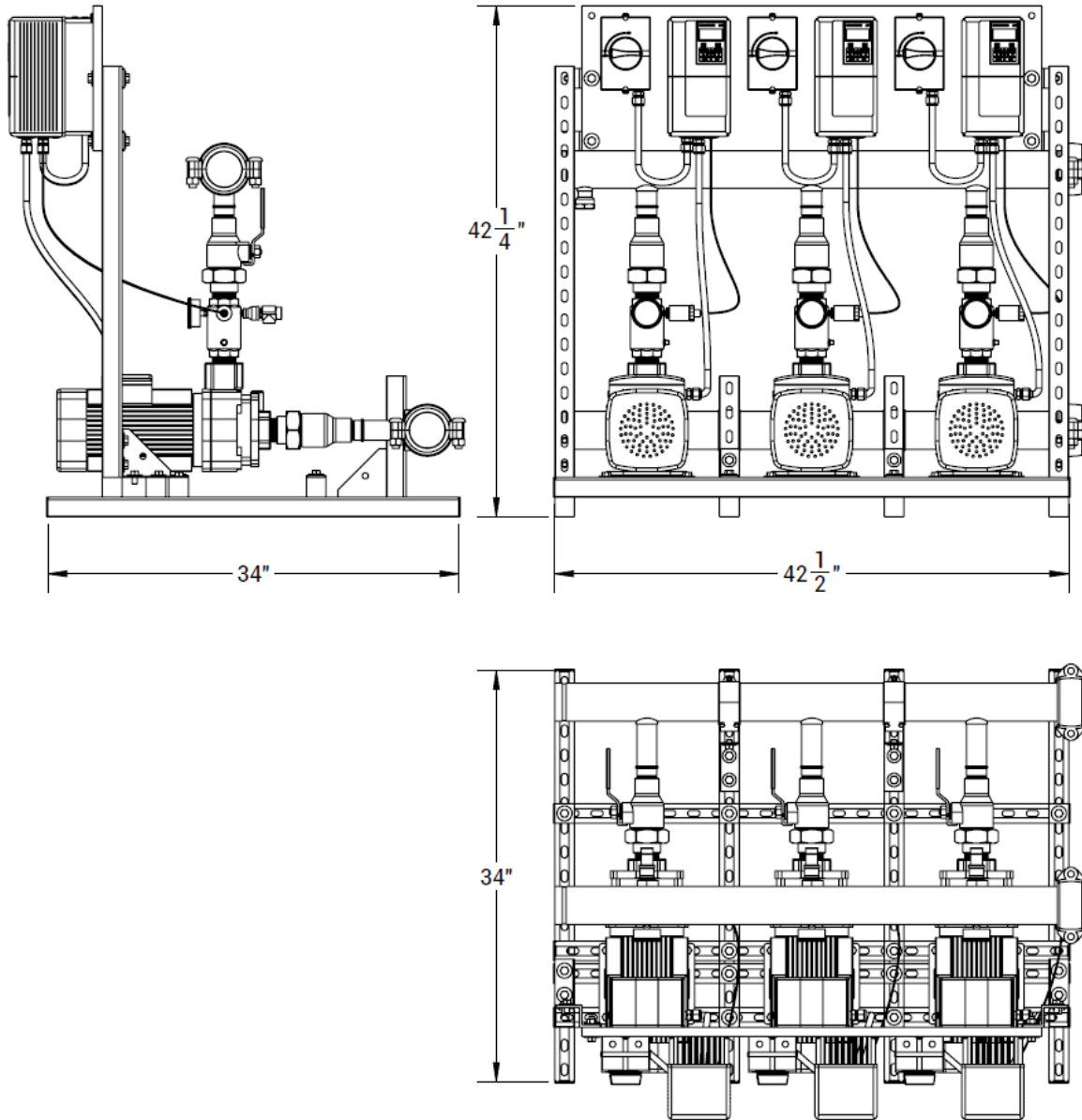

**PROPRIETARY AND CONFIDENTIAL**  
THE INFORMATION CONTAINED IN THIS DRAWING IS THE SOLE PROPERTY OF TOWLE WHITNEY LLC. ANY REPRODUCTION IN PART OR AS A WHOLE WITHOUT THE WRITTEN PERMISSION OF TOWLE WHITNEY LLC IS PROHIBITED.

DIMENSIONS ARE SUBJECT TO CHANGE  
DO NOT USE FOR CONSTRUCTION  
UNLESS OTHERWISE SPECIFIED  
DIMENSIONS ARE IN INCHES

DO NOT SCALE DRAWING

	NAME	DATE
DRAWN:	VID	10/12/22
CHECKED:	DW	10/12/22
COMMENTS:		

**TOWLE WHITNEY LLC**

**Triplex Variable Speed Booster System**

SIZE: **A** DWG. NO. **2022-10-12-B**

SCALE: 1:24 WEIGHT:

SHEET 1 OF 1

**Assembled Units:**

- All “wetted surfaces” shall be lead free (<.25% Pb) in conformance with the 1/4/14 federal law
- Shall include a separate and independent variable frequency drive (VFD) for each pump with a pressure transducer, pressure gauge, and relief valve. Piping and frame shall not interfere with access to the controls
- Each pump shall include isolation valves on both the suction and discharge piping
- Each pump shall have a separate and independent disconnect box
- Shall be mounted on a frame for ease of transport and installation.

**Variable frequency drive:**

- Will ALTERNATE the lead pump every 24 hours (field adjustable) of run time. The lag pump shall be in standby
- Shall have hands-off automatic (HOA) capability
- Rated to operate using specified power requirement. The drive efficiency shall be 98% or better
- Have UL approval with all factory installed options and preset values and/or last saved data values will remain available to the operator after power outage
- Shall have at least NEMA 1 rated conduit enclosure
- The program will protect the pumps against damaging hydraulic conditions such as:
  - Motor overload, Pump overflow surges, Loss of prime due to incoming water supply interruption, Hunting
  - Protection from overload through frequency/current optimization
  - Protection from hydraulic damage by restricting the pumps to operate beyond their published end of curve
- Shall have the ability to automatically restart after an over-current, over-voltage, under-voltage or loss of input signal
- Shall have an operator control panel [keypad] for customization of parameters
- Shall include a feature to upload/download parameters into an external device to be used with another drive or the same drive
- Shall have a removable non-volatile memory device
- Shall be capable of accepting individual analog inputs from transducer. All transducer inputs must be wired to the variable frequency drive for continuous scan and comparison function
- Ladder logic program shall utilize a proportional - integral - derivative control function
- Shall display the following values:
  - Pump running/standby, Pump speed in Hz, User adjustable parameters such as PID set points, Motor frequency, Motor current, Threshold set points for PID error, Min operating frequency, Troubleshooting and diagnostics of faults

**Transducer:**

- The transducer shall be rated for required system pressure and shall be 4-20 mA analog
- Separate transducers shall be supplied for each variable frequency drive to ensure redundancy

**Centrifugal pump:**

- Shall have a stainless steel casing with 304 stainless steel impellers.
- Shall have a 316 stainless steel shaft sleeve. Mechanical seal shall be rated to withstand pressure of up to 142 PSI
- Motor shall be to totally enclosed fan cooled (TEFC). and manufactured in compliance with CE, RoHS and CSA

**Pneumatic expansion tank:**

- Pneumatic expansion tank shall be rated for use with potable water with an operating pressure of a maximum 125 PSI
- Pre-charged to a pressure of 10 PSI below system operating pressure for system to run properly

**Manifolds, valves and fittings:**



- Manifolds are designed for either right or left access
- Shall be sized appropriately to allow water velocity not exceeding 10 ft/sec, to minimize cavitation and turbulence
- Check valves shall be silent and spring-loaded

**Installation:**





- Equipment shall be installed in accordance with applicable local building, electrical and plumbing codes
- Shall be installed indoors (unless otherwise specified) and protected from water spray

**COMPONENT COMPLIANCE**

**Electrical**

Yaskawa VFD	UL 508C Power Conversion CSA 22.2 Industrial Controls		CE	<b>RoHS</b>
Lovato Shut-off	NEMA4		CE	<b>RoHS</b>

**Pumps**

Grundfos CM(I) SS Series	NSF 61		CE	
Grundfos CR(I) SS Series	NSF 61		CE	
Goulds 125MS Series	NSF 61		CE	
Goulds BF Series	NSF 61		CE	
Walrus TPH Series	NSF 372		CE	<b>RoHS</b>

**Plumbing**

Bluefin BVT200 Ball Valves	NSF 61			
Webstone BVT200 Ball Valves	NSF 61			
Bonomi Check 1000012	NSF 61		CE	
Flomatic VFD Check	NSF 61			
Victaulic 607 "E" Coupling	NSF 61			
Victaulic 660 Cap	NSF 61			
Amtrol PL Tank	NSF 61			
Watts PLT Tank	NSF 61			
Manifolds / piping	Type L Copper			
Fittings	Copper			
Discharge Riser	Copper		CE	
- Pressure Relief valve:				
- SS 4-20mA Transducer:				
- Pressure Gauges:	CA AB1953			

**Sealants**

Rectorseal Nokorode Flux	NSF 61
Worthington SILVER Solder	NSF 61
LocTite 567 Thread Sealant	NSF 61
Gasola Thread Sealant	NSF 61





**Warranty:** Provide VFD warranty, for one year from startup, not to exceed 18 months from the date of shipment. Warranty shall include parts, and labor allowance for repair hours.



**Performance Features (Drive)**

- Ratings:  
1 to 5 HP at 200-240 VAC 1-Ph.  
1 to 25 HP (ND) at 200-240 VAC 3-Ph.  
1 to 25 HP (ND) at 380-480 VAC 3-Ph.
- Overload Capacity:  
120% for 60 sec. (Normal Duty)
- Control Methods: V/f Control,  
Open Loop Current Vector Control
- DC injection braking, ramp to stop
- Electronic reversing
- Adjustable accel/decel: 0.01 to 6000 seconds
- Controlled speed range:  
40:1<sup>(1)</sup> 100:1<sup>(2)</sup>
- Speed Regulation:  
± 0.5 to 1% with slip compensation<sup>(1)</sup>  
± 0.2%<sup>(2)</sup>
- Displacement power factor: 0.98
- Output frequency: 0 to 400 Hz
- Frequency resolution:  
0.01 Hz with digital reference  
0.06 / 60 Hz with analog reference
- Frequency accuracy:  
0.01% with digital command  
0.5% with analog command
- Volts / hertz ratio: infinitely adjustable pattern
- DC Injection braking: adjustable amplitude, duration, current limited
- Torque boost: full range, auto
- Power loss ride-thru: 0.5 sec.
- Speed search
- Auto restart
- 3 Critical frequency rejection settings
- Slip Compensation
- Energy Savings Function
- Enhanced PID with loss of feedback function

<sup>(1)</sup> V/f Mode

<sup>(2)</sup> Open Loop Current Vector Mode

**Design Features (Drive)**

- Dual microprocessor logic
- Digital keypad operator, 5 digits
- LED status display
- Remote Mount Keypad Capability
- RJ-45 Style Digital Operator Connector
- 7 multifunction digital inputs
- 3 multifunction digital outputs
- Hardwire baseblock (EN954-1 Cat. 3)
- Programmable form C output contact for customer use: 1A at 250 VAC or 30 VDC
- 24 VDC control logic compatible with sourcing or sinking outputs (PNP or NPN)
- Carrier frequency: 15 kHz max; swing PWM
- 2 Remote speed references:  
0-10 VDC (20 kohms) or isolated 4-20 mA (250 ohms)
- Signal follower: bias and gain
- 2 programmable open collector outputs
- Analog monitor output:  
0-10 VDC proportional to output frequency or output current
- Approx. 400 parameters and monitors
- Digital pulse train input (33 kHz max.)
- Cooling fan controlled by drive run/stop
- RS-422/485 Modbus 115 kbps
- UL recognized electronic overload
- MTBF: 28 years
- NEMA 1 enclosure
- Side-by-Side mounting
- Maintenance monitors

**Protective Features (Drive)**

- Current limit, stall prevention during accel, decel, and run
- Motor and drive overload
- Over voltage prevention function
- Instantaneous over current
- Short circuit
- Under voltage
- Heatsink overheat
- Ground fault protection
- Over/under torque
- Short circuit current rating: 30kA rms sym.

**Pump Control Features**

- Operator keypad with intuitive pump language
- Hand-Off-Auto
- Programmable pump process set point
- Pump start level and start time
- Sleep protection
- Simplex, duplex and triplex control
- Automatic system restart
- No flow detection
- Low and high feedback set points
- Pre-charge low level control
- Thrust bearing control
- Automatic system stabilization
- Motor condensation pre-heat function

**Pump Protective Features**

- Dry well
- Air in system
- Blocked impeller
- Pump over cycling
- No flow protection
- Loss of prime
- Transducer loss
- Over torque

**Pump Alarms and Messages**

- Low feedback
- High feedback
- Low level
- Low water
- Pump over cycling
- No flow detection
- Loss of prime
- Pump fault
- Motor thermostat
- Pre-charge mode
- Thrust bearing active
- Start mode active
- Sleep mode active

**PUMP**

**SPECIFICATIONS**

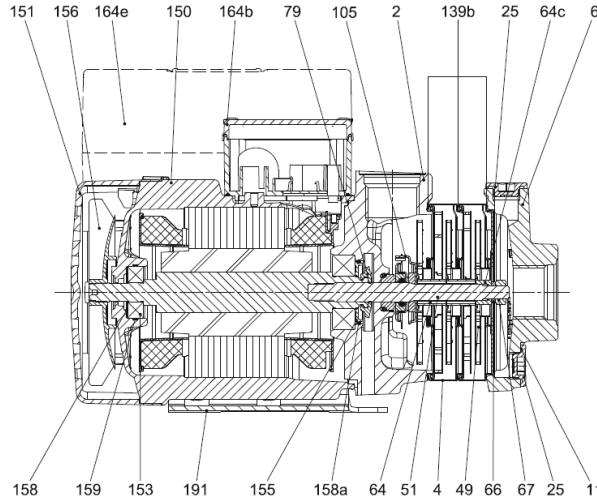

TM04 3723-989

Fig. 7 CM(E) 1-3 with ML(E) 71 motor

**Components**

Pos.	Component	Pos.	Component	Pos.	Component
2	Discharge part	64c	Clamp	153	Ball bearing
4	Chamber	66	Washer (NORD-LOCK®)	155	Bearing cover plate
6	Inlet part	67	Nut	156	Fan
11	O-ring	79	Diverting disc	158	Corrugated spring
25	Plug	105	Shaft seal	158a	O-ring
49	Impeller	139b	Gasket	159	O-ring
51	Pump shaft	150	Stator housing	164b, 164e	Terminal box
64	Spacing pipe	151	Fan cover	191	Base plate

**CM 10-I and CM 10-G**

(I = EN 1.4301/AISI 304 and G = EN 1.4401/AISI 316)

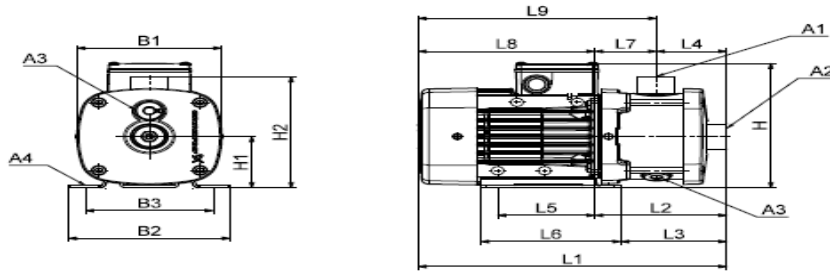

TM04 2246-238

**Dimensions**

3 x 208-230 V / 440-480 V, 60 Hz (supply voltage E)  
3 x 575 V, 60 Hz (supply voltage H)

Pump type	Frame size	P <sub>2</sub> [hp]	NPT			Rp	Dimensions [in (mm)]														
			A1	A2	A3		A4	B1	B2	B3	H	H1	H2	L1	L2	L3	L4	L5	L6	L7	L8
CM 10-1	80	1.7	1 1/2"	1 1/2"	3/8"	0.39 (10)	7.09 (180)	8.22 (189)	4.92 (125)	8.50 (216)	3.94 (100)	8.58 (218)	15.71 (399)	7.28 (185)	6.34 (161)	4.13 (105)	3.78 (96)	5.39 (137)	4.15 (80)	8.43 (214)	11.57 (294)
CM 10-2*	90	3.4	1 1/2"	1 1/2"	3/8"	0.39 (10)	7.09 (180)	7.84 (199)	6.30 (160)	8.27 (210)	3.94 (100)	8.58 (218)	17.72 (450)	7.05 (179)	6.46 (164)	4.13 (105)	5.51 (140)	6.69 (170)	2.91 (74)	10.71 (272)	13.56 (345)
CM 10-3*	100	5.4	1 1/2"	1 1/2"	3/8"	0.39 (10)	7.80 (198)	7.84 (199)	6.30 (160)	8.66 (220)	3.94 (100)	8.58 (218)	19.96 (507)	9.25 (235)	8.66 (220)	4.13 (105)	5.51 (140)	6.69 (170)	5.12 (130)	10.71 (272)	15.83 (402)
CM 10-4*	112	8.4	1 1/2"	1 1/2"	3/8"	.47 (12)	8.66 (220)	8.98 (228)	7.48 (190)	9.69 (246)	4.41 (112)	9.06 (230)	23.19 (589)	11.30 (287)	10.67 (271)	5.32 (135)	5.51 (140)	6.77 (172)	5.98 (152)	11.89 (302)	17.87 (454)
CM 10-5*	112	8.4	1 1/2"	1 1/2"	3/8"	.47 (12)	8.66 (220)	8.98 (228)	7.48 (190)	9.69 (246)	4.41 (112)	9.06 (230)	25.55 (649)	13.06 (347)	13.03 (331)	7.68 (195)	5.51 (140)	6.77 (172)	5.98 (152)	11.89 (302)	17.87 (454)

\* This pump type is not available with supply voltage O.

**1 x 115/230 V, 60 Hz (supply voltage B)**

Pump type	Frame size	P <sub>2</sub> [hp]	NPT			Rp	Dimensions [in (mm)]														
			A1	A2	A3		A4	B1	B2	B3	H	H1	H2	L1	L2	L3	L4	L5	L6	L7	L8
CM 10-1	80	1.5	1 1/2"	1 1/2"	3/8"	0.39 (10)	8.07 (205)	8.22 (185)	4.92 (125)	9.17 (233)	3.94 (100)	8.58 (218)	15.71 (399)	7.28 (185)	6.34 (161)	4.13 (105)	3.78 (96)	5.39 (137)	4.15 (80)	8.43 (214)	11.57 (294)



**PNEUMATIC EXPANSION TANK SPECIFICATIONS**



**PRO-LINE®**  
Diaphragm Well Tanks: PL Series

**125 PSIG Working Pressure**

**Construction**

Shell	Deep Drawn Steel
Diaphragm	Butyl
Liner	Polypropylene
System Connection	304L Stainless Steel
Finish	Tan
Water Circulator	Turbulator™
Air Valve	Projection Welded
Factory Precharge	38 PSIG (2.6 bar)

**Application**

• Controls pump cycling in residential well water systems.

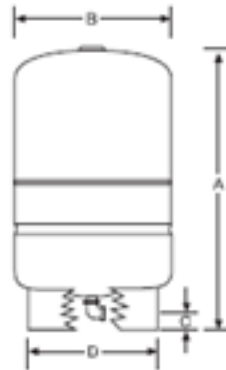

**Performance**

Maximum Operating Temperature	200°F (93°C)
Maximum Working Pressure	125 PSIG (8.6 bar)
Maximum Relief Valve Setting	100 PSIG (6.9 bar)
Warranty	5 Year

**Stand Models**

Model	Tank Volume		Max. Accept. Factor	A Tank Height		B Tank Diameter		C Sys. Conn. Centerline		D Stand Diameter		System Conn. (NPTF)	Shipping Weight	
	Gal	Lit		in	mm	in	mm	in	mm	in	mm		Lbs	Kg
PL-14	14.0	53	0.81	25	635	15	381	1 1/4	40	12	304	1	22	10
PL-20	20.0	76	0.67	32	813	15	381	1 1/4	40	12	304	1	28	13
PL-26	26.0	98	0.44	39	991	15	381	1 1/4	40	12	304	1	34	15
PL-32	32.0	121	0.35	47	1194	15	381	1 1/4	40	12	304	1	40	18
PL-34	34.0	129	1.00	30	762	22	559	1 1/4	49	20 1/2	521	1 1/4	50	23
PL-44	44.0	167	0.77	38	914	22	559	1 1/4	49	20 1/2	521	1 1/4	57	26
PL-62	62.0	235	0.55	47	1194	22	559	1 1/4	49	20 1/2	521	1 1/4	75	34
PL-81	81.0	301	0.41	57	1448	22	559	1 1/4	49	20 1/2	521	1 1/4	92	42
PL-86	86.0	326	0.54	47	1194	26	660	2 1/4	52	20 1/2	521	1 1/4	99	45
PL-119	119.0	450	0.39	62	1575	26	660	2 1/4	52	20 1/2	521	1 1/4	133	60

All dimensions and weights are approximate.



## **Booster Pump Systems**

### **Three Year Limited Warranty**

This warranty applies to booster pump systems built by Towle Whitney LLC, and shall:

- Exist 36 months from the date of shipment.
- Be in effect only after installation photographs are received by Towle Whitney LLC.

Towle Whitney LLC liability under this warranty shall be limited to the repair or replacement of any part or parts found to be defective (material or workmanship) within the warranty period. Towle Whitney LLC shall determine whether the part needs to be returned, or field scrapped. The warranty excludes:

- Any water damage or consequential damage.
- Transducers & Pump Seals.
- Debris in water causing damage to pump internal parts.
- Systems not installed in accordance with Installation and Maintenance Instructions.
- Labor, transportation, and related costs incurred by the customer.
- Misuse, negligence, inappropriate chemicals or additives in water.
- Inadequate protection from freezing.
- Lightning, high voltage spikes, accidents, floods, or acts of God.
- Re-Installation costs of repaired or replacement equipment.
- Re-Imbursement for the loss caused by interruption of service.
- Adjusting drive parameters without consulting Towle Whitney.

This warranty applies to all states and territories of the United States and Canada only. There are no express or implied warranties, including merchantability or fitness for a particular purpose, which extend beyond those warranties described or referred to above.

Some jurisdictions do not allow the exclusion or limitation of incidental or consequential damages and some jurisdictions do not allow limit actions on how long implied warranties may last. Therefore, the above limitations or exclusions may not apply. This warranty gives you specific legal rights and you may also have other rights which vary from jurisdiction to jurisdiction.