

Instruction and Operation Manual

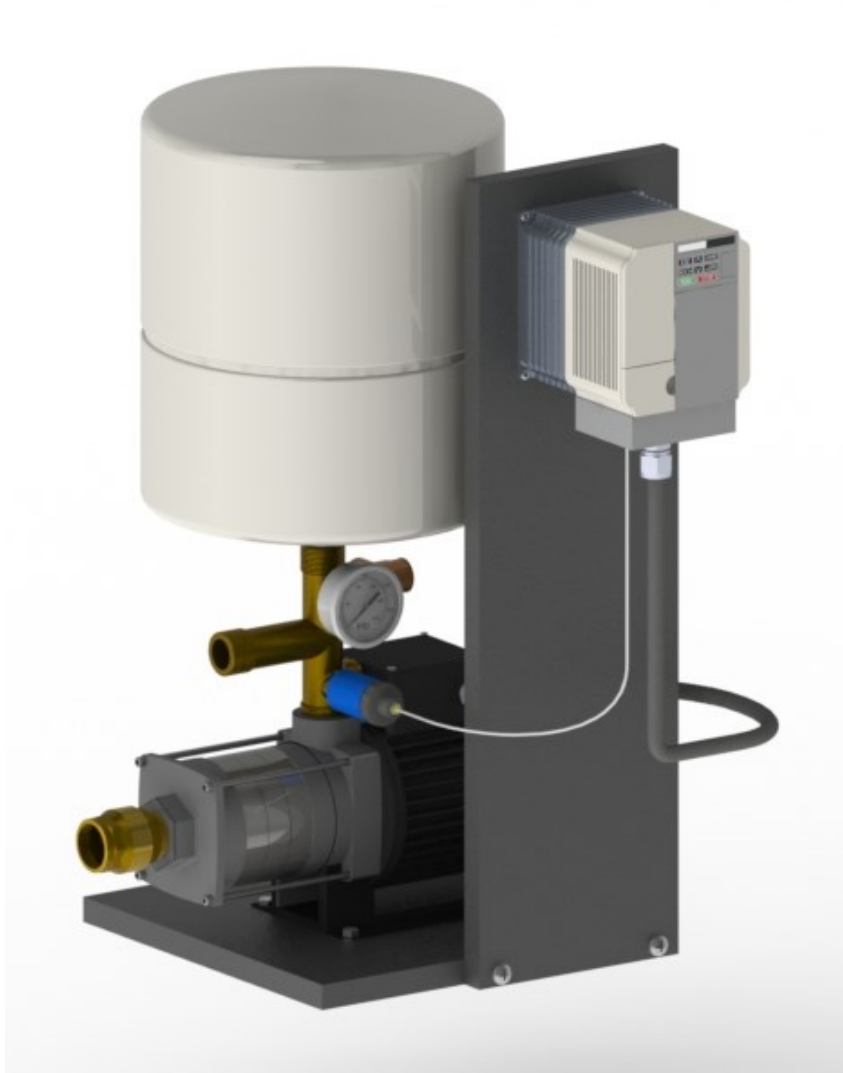

Flag Frame Variable Speed Booster Systems *[Walrus, Yaskawa]*

Safety Instructions



WARNING! Plumbing code requirements for a closed system:

The check valve installed on the suction side of the booster pump system creates a closed system which restricts backflow of water and can affect the water heater T&P Safety Relief Valve. If your T&P Safety Relief Valve starts to leak water please address the thermal expansion issue by installing a properly sized thermal expansion tank for your water heater. **The thermal expansion tank provided with the Towle Whitney Booster Pump System is adequate for our booster pump system only and will not address the water heater thermal expansion issue.**



WARNING! A Towle Whitney variable speed booster system must ALWAYS be protected from the elements of wash down, water spray, rain, sun, and humidity, etc. [unless Booster Pump System has NEMA 4 upgrade].

All local building, electrical and plumbing codes must be followed while installing and operating a TW Booster System.

PRE-WIRED
&
TESTED

Note: Your pump system has been assembled, power tested, and water tested against leaks in our factory. Some residual pipe sealant and water may be left in the pump and piping.

You will enjoy great pressure and energy savings from our Booster Pump System!

Thank you for your purchase!

Check List

Follow local building, electrical, and plumbing codes during installation.

Call us with any questions or startup issues. 1-603-626-7371 or 1-800-807-9827

System Installation

___ Verify all parts are in kit. **[Components / Tank Tee Assembly]**

___ Install check valve and parts on pump discharge. Follow directions **[Components / Tank Tee Assembly]**

___ Mount VF Drive and make electrical connections to VF Drive as required.

Follow directions **[VF Drive & Wiring Installation]**

___ Wire VF Drive to Pump. Follow directions **[VF Drive & Wiring Installation]**

___ Install check valve. **[Check Valve Installation]**

___ Install ball valves on suction and discharge lines when piping system (We also recommend installing unions).

Follow directions **[Piping Instructions]**. **Three Valve Bypass Option is recommended.**

___ Install Pneumatic Expansion Tank. Follow directions **[Expansion Tank Instructions]**.

___ Ready for Start up. Follow directions **[Start up]**

___ Refer to troubleshooting page for troubleshooting. **[Troubleshooting]**

___ Look for Blue and White Serial Number Sticker on frame and record number here for future.

___ Email pictures of installation to info@towle-whitney.com for warranty purposes. Include Serial Number.



Components / Tank Tee Assembly

GETTING STARTED

Verify that all parts are included in your kit:

PARTS FOR SUCTION:

- ___ Check valve
- ___ Nipple

PARTS FOR DISCHARGE:

- ___ Tank tee
- ___ Plug

COMPONENTS:

- ___ Pump on Frame
- ___ VF Drive on Frame
- ___ Pneumatic Tank
- ___ Pressure Gauge
- ___ Transducer
- ___ Relief Valve
- ___ Literature

Tank Tee Assembly:



Picture of complete tank tee assembly

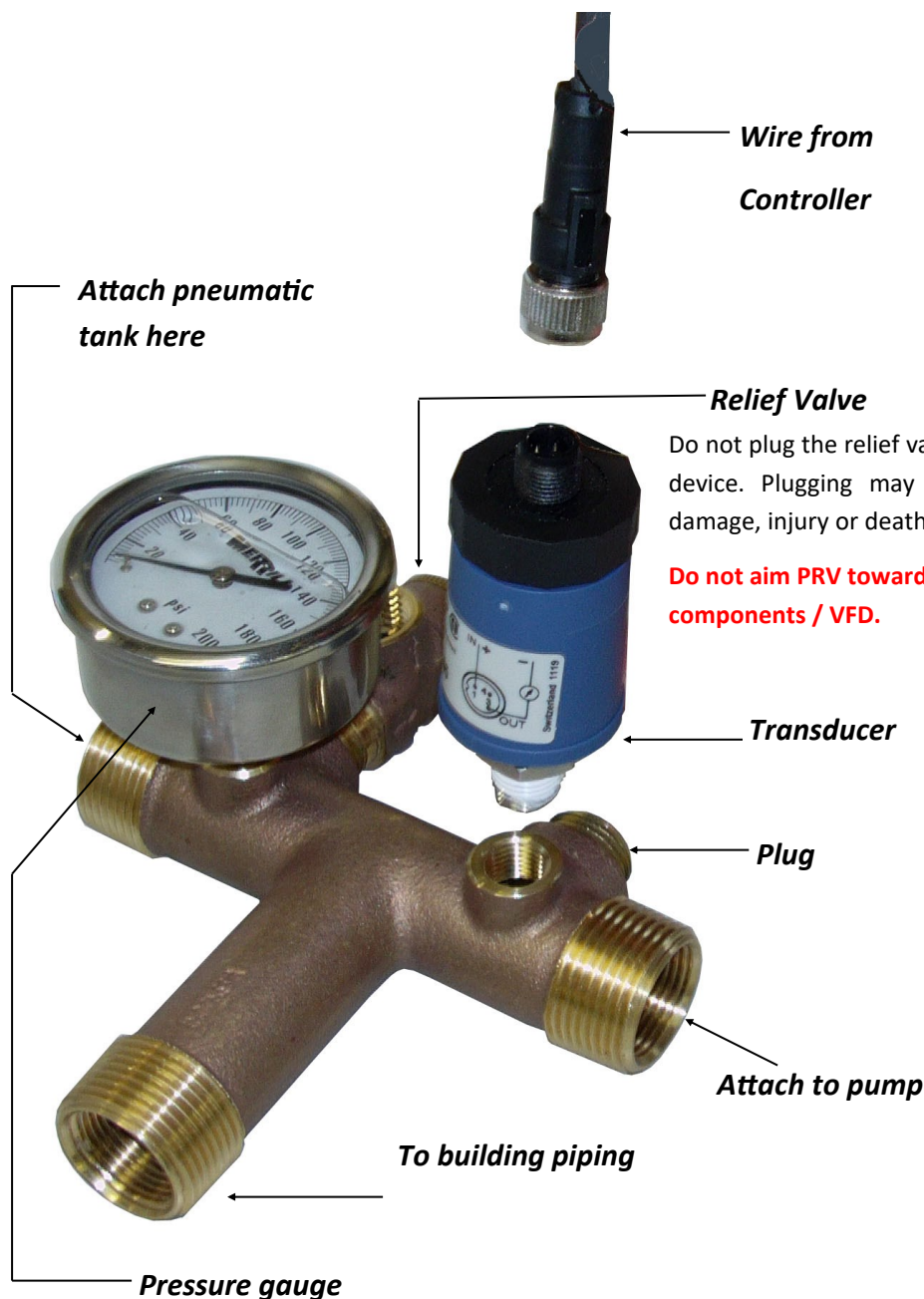

Follow procedure to attach the Tank tee to the pump:

(use pipe sealant or Teflon tape)

1. Attach Tank Tee to pump discharge.
2. Attach relief valve, plug and pressure gauge in locations shown in the figure.
3. Attach the transducer to the Tank Tee.
4. Attach the wire from VF Drive to the transducer.

230V VF Drive & Wiring Instructions

STEP 1: Remove the two screws from the bottom side of the pump plate.

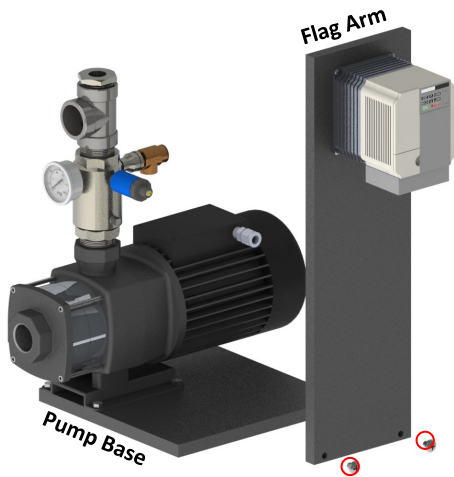

STEP 2: Attach the Flag Arm to the Frame Base using the two screws.

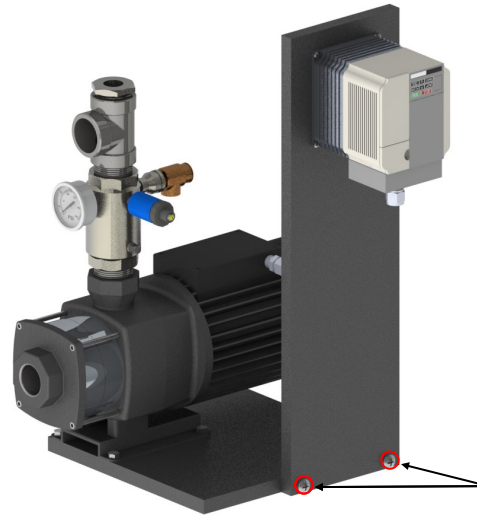

STEP 3: Attach the wires from the VF Drive to the Electrical Panel according to power supplied

***We recommend a disconnect switch be located near system.**

STEP 4: Attach the wires from the VF Drive to the Pump as follows:

Attach the **RED [U]** Wire from the VF Drive to the U1-U5 wire in the pump electrical box

Attach the **BLACK [V]** Wire from the VF Drive to the V1-V5 wire in the pump electrical box

Attach the **WHITE [W]** Wire from the VF Drive to the W1-W5 wire in the pump electrical box

Attach the **GREEN [GND]** Wire from the VF Drive to the GND screw in the pump electrical box

Tie U2, V2, W2 together in wire nut

PUMP ELECTRICAL BOX

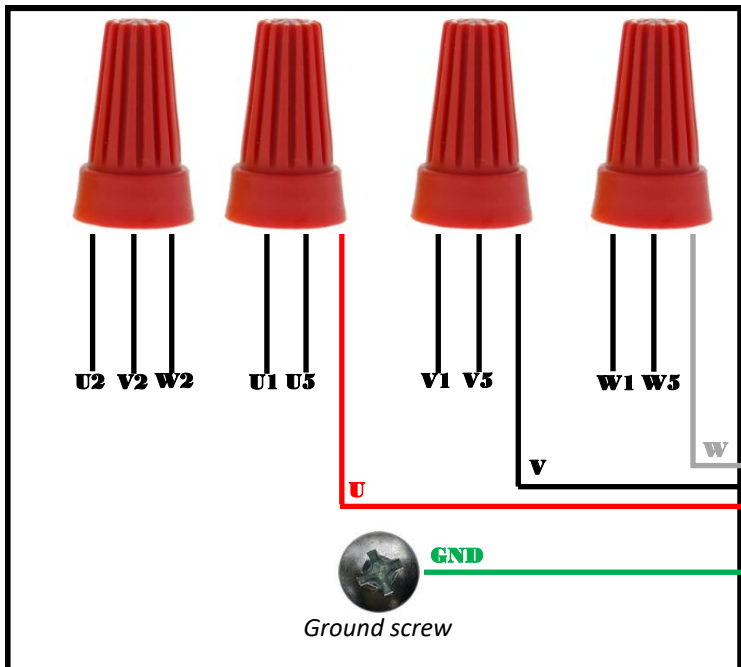

VF Drive



***230V**

Motor wiring

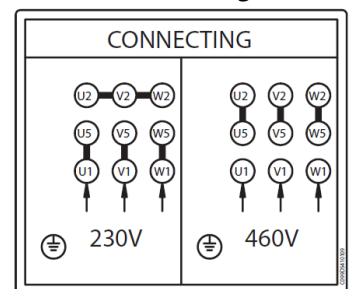

480V VF Drive & Wiring Instructions

STEP 1: Remove the two screws from the bottom side of the pump plate.

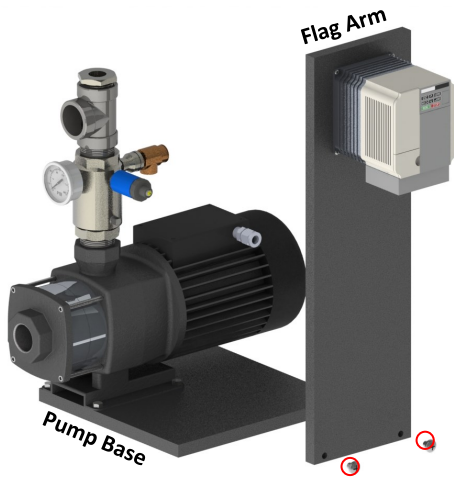

STEP 2: Attach the Flag Arm to the Frame Base using the two screws.

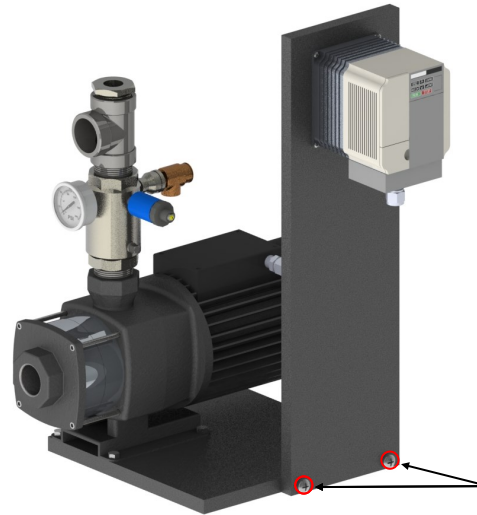

STEP 3: Attach the wires from the VF Drive to the Electrical Panel according to power supplied

***We recommend a disconnect switch be located near system.**

STEP 4: Attach the wires from the VF Drive to the Pump as follows:

Attach the **RED [U]** Wire from the VF Drive to the U1 wire in the pump electrical box

Attach the **BLACK [V]** Wire from the VF Drive to the V1 wire in the pump electrical box

Attach the **WHITE [W]** Wire from the VF Drive to the W1 wire in the pump electrical box

Attach the **GREEN [GND]** Wire from the VF Drive to the GND screw in the pump electrical box

Pump electrical box

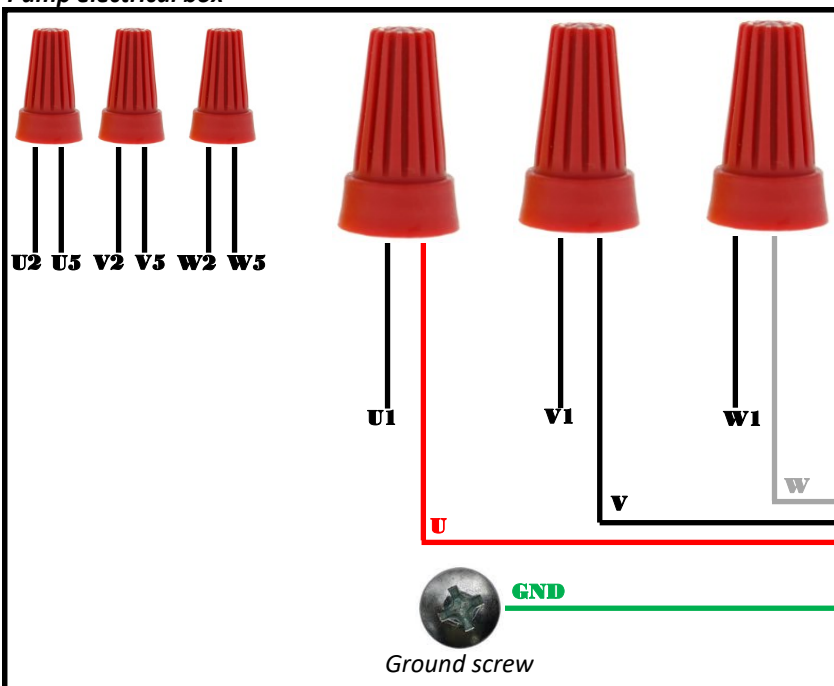

VF Drive

***480V**

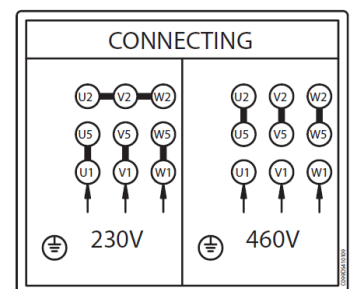

Check Valve Installation

Check Valve Install

Caution: DO NOT USE TEFLON TAPE TO INSTALL CHECK VALVE

Teflon tape may foul the check valve. Only use pipe sealant such as Loctite.

Teflon tape is acceptable between the nipple and pump.

If pump casing parts are twisted out of alignment, the pump may make noise and/or the internal components may be damaged

- Install nipple and check valve [**embossed arrow must be pointing toward pump**] on the suction side of pump.
- Care must be taken to **prevent twisting of the pump casing** when installing the fittings on the pump suction [brass nipple, check valve and piping].
- In order to install fittings securely, use two adjustable wrenches so that the pump housing does not twist out of its original position.
- To achieve desired pump performance, a very accurate alignment of the impeller housing parts must be maintained.



Use adjustable wrenches to hold the casing in place.

Do not twist casing to avoid damage to the pump

Mandatory Installation

Towle Whitney requires a ball valve be installed on the discharge and suction of the booster pump system.

Follow diagram.

This is mandatory.

Our technician can only troubleshoot issues if this is done.

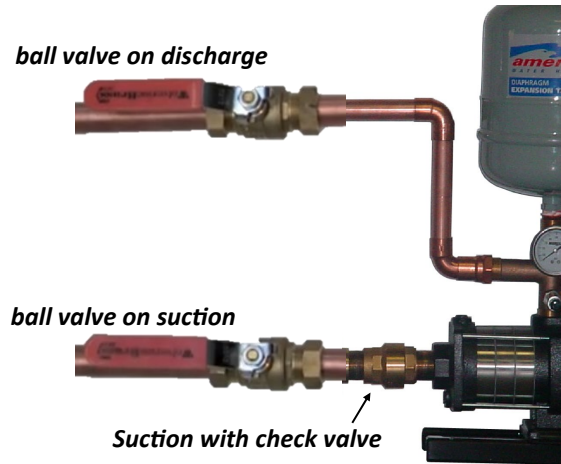

Three Valve Bypass Option

When utilizing pump system.

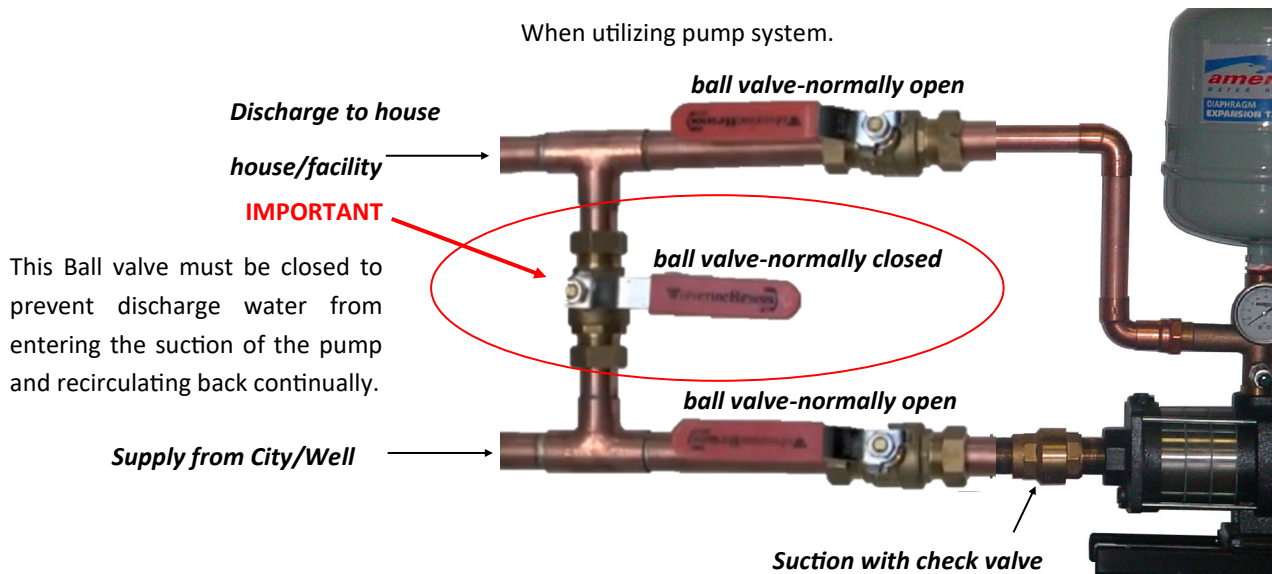

A Three Valve Bypass line is recommended. Once installed: To bypass the pump system simply close ball valves on suction and discharge and open normally closed ball valve. Especially helpful during a power outage and it will also allow for servicing the pump system.

HOW TO BYPASS BOOSTER PUMP SYSTEM

- Close normally open ball valves [handles will be not be aligned with the pipe]
- Open normally closed ball valve [handle will be in line with pipe]

Expansion Tank Instructions

Pneumatic Tank Install

Pneumatic Tank is preset at the factory. It is recommended that you check the pressure in the tank before attaching to the pump system. A tire gauge can be used. Verify that the pressure is correct at 10 psi below your system set pressure. Add air into pneumatic tank to correct pressure. Now you are ready to install pneumatic tank [using Teflon tape or pipe sealant] on the top of tank tee or to the side of tank tee if space is restricted.

Pneumatic Tank pressure MUST be

10 PSI less than system set pressure.

This allows pump system to work properly.

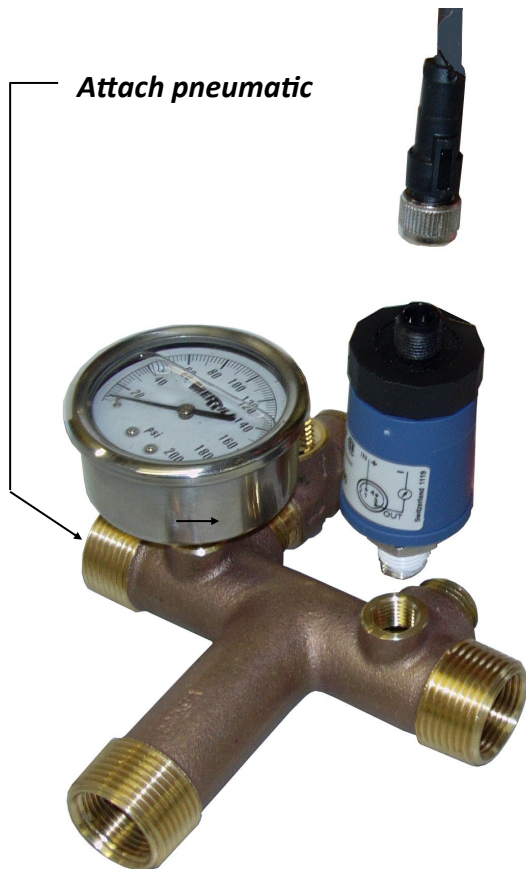

Floor Mount Tanks:

Connect to 1" busing provided on discharge tee. It is recommended to have a ball valve for isolating the pneumatic tank and a boiler drain to remove water from the tank for maintenance, replacement or changing tank air pressure.

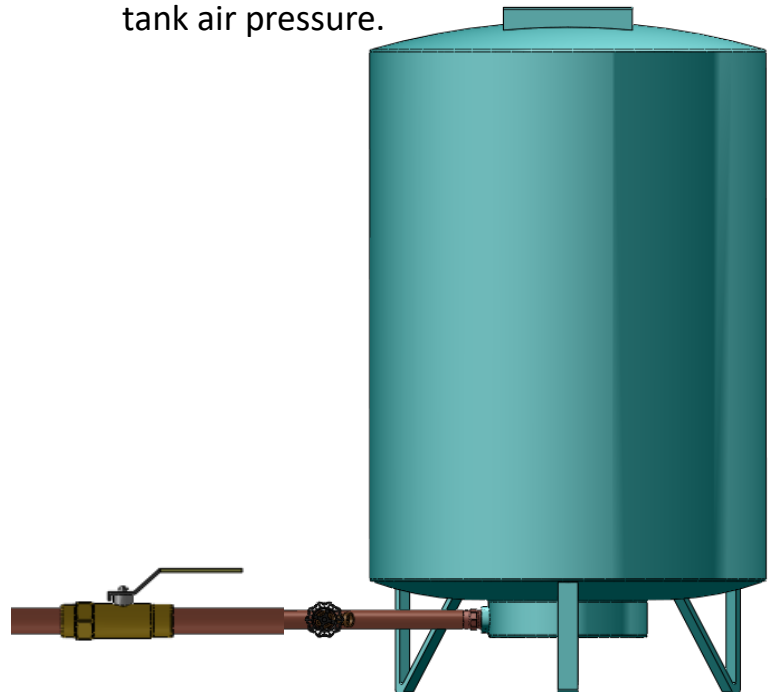

Yaskawa VF Drive

NOTE: The VF Drive is factory preset. DO NOT change the settings in the VF Drive.

Make the necessary power connections based on the type of power.

Do not power up system yet

System Start-up:

- Fill pump with water by opening supply line to pump and then turn on a faucet downstream. This will fill the pump with water and displace air from pump impellers / piping. Wait a couple of minutes before proceeding.
- Turn on circuit breaker for pump system.
- Once power is provided, press AUTO button on controller. Pump will start automatically.
 - I. If Pump System does not turn on automatically, open additional faucets to create more water demand. The pump will start when line pressure drops 5 PSI below system set pressure.
- Once all the air is displaced, close faucet(s). Pump will automatically stop when there is no water demand.
- You are ready to enjoy great water pressure!



Troubleshooting

CALL US WITH ANY UNRESOLVED ISSUES: 603-626-7371 OR 800-807-9827

Loss of incoming water supply:

- Systems are programmed to stop and start automatically upon loss/restoration of incoming water supply. However, if the pump system does not start normal operation automatically, turn off appropriate circuit breaker, wait until the VF Drive display goes blank and turn the power ON by plugging into outlet or turning on circuit breaker.

Loss of power supply:

- If Pump System does not turn on automatically, turn off the system using appropriate circuit breaker, wait until the VF Drive display goes blank. Turn the system ON by plugging into outlet or turning on circuit breaker.

Short cycling:

Issue:

- Pump turns ON / OFF every few minutes / seconds

Solution:

- Check for leaks in the line going from the pump to the building.
- As mentioned in the assembly section, it is essential to install a ball valve on the suction [City/ Well side] and discharge [Building side] of the pump. Close the ball valve on the discharge side of the pump and check to see if the pump turns OFF. If it does, there may be a leak in the water line, a faucet, a toilet, hose bib etc. If the pump continues to run after the shut off valve is OFF, the water may be leaking back through the check valve. Shut ball valve on pump suction side, if pump remains running then check valve is fouled and has something in it. Check valve debris must be flushed out by running a lot of water through system or removed and cleaned of debris.

Pump continually runs:

Issue:

- Pump operates constantly without any demand for water

Solution:

- Air may be present in the line going from the pump to the building. Open faucets to purge air out. When all fixtures are closed and no water is being drawn, air may get trapped within the lines causing the pump to not reach the pressure set point and hence cause it to operate continuously.

Pump Shaft Noise:

Issue:

- There is a squeaking noise at the end of a pump duty cycle.

Solution:

- Lubricate the shaft through the gap between the pump casing and the motor.