



**TW1000-70W-50 FLAG FRAME
VARIABLE SPEED BOOSTER SYSTEM**

TW1000-70W-50 FLAG FRAME

The *TW1000-70W-50 Flag Frame Booster System* is equipped with a centrifugal pump regulated by a variable frequency drive that controls the pump operation to maintain constant pressure regardless of varying demand or fluctuation in incoming pressure.

Features and Benefits:

- Quiet, Compact & Powerful
- Variable Frequency Drive controlled pump
- Energy efficient operation
- Prewired & Factory Tested

Lead-Free* (Wetted) components:

- Centrifugal Pump: Cast iron (SS upgrade available)
- Relief valve: Lead Free Brass
- Pressure Gauge: Lead Free Brass
- Transducer: Stainless Steel
- Tee: Stainless Steel
- Check valve: Stainless Steel
- Fittings: Stainless Steel

*All lead-free brass shall contain <.25% Pb

Technical Specifications:

Pump: Walrus of America [12T-4K]
Horse Power: 3 HP

Controller: Yaskawa

Flow Rate: 70 GPM
Boost: 50 PSI Overboost

Suction: 1 1/2 inch
Discharge: 1 1/2 inch

Tank: 8.5 Gallon [PLT-20]
Frame Size: 22" W x 24" H x 17" D
Decibel rating: <80 db @ 3500 RPM

Power Options: Independent circuit required
208-220V/ 1PH
208-220V/ 3PH
360-480V/3PH
Specify when ordering



*All parts shown are included in the system
Actual system components may vary
Some assembly required*

Pump performance curve

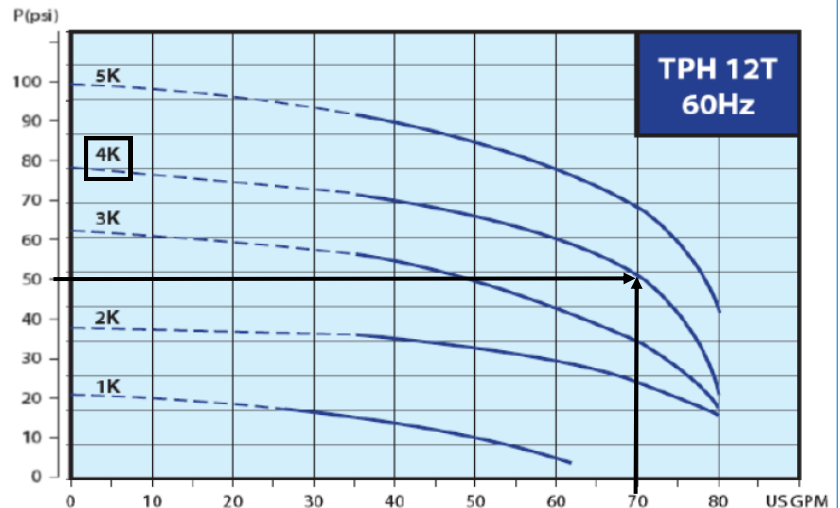

SYSTEM CONFIGURATION

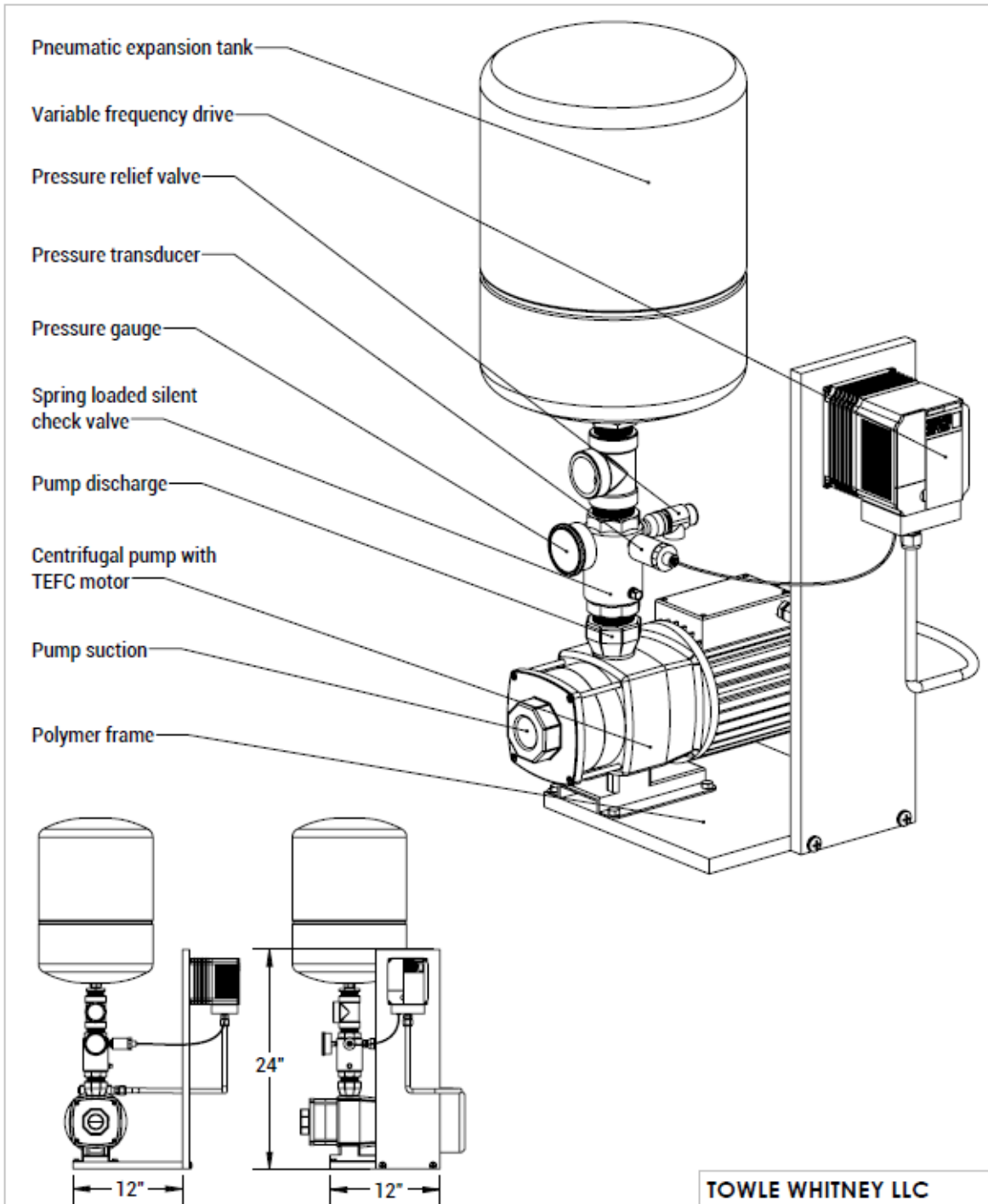

PROPRIETARY AND CONFIDENTIAL
THE INFORMATION CONTAINED IN THIS DRAWING IS THE SOLE PROPERTY OF TOWLE WHITNEY LLC. ANY REPRODUCTION IN PART OR AS A WHOLE WITHOUT THE WRITTEN PERMISSION OF TOWLE WHITNEY LLC IS PROHIBITED.

DIMENSIONS ARE SUBJECT TO CHANGE
DO NOT USE FOR CONSTRUCTION
UNLESS OTHERWISE SPECIFIED
DIMENSIONS ARE IN INCHES

DO NOT SCALE DRAWING

NAME	DATE
DRAWN: VID	4/20/23
CHECKED: DW	4/20/23
COMMENTS:	

TOWLE WHITNEY LLC	
Flag Frame Variable Speed Booster System	
SIZE: A	DWG. NO. 2023-04-20-B
SCALE: 1:12	WIDGHT: SHEET 1 OF 1

Assembled Units:

- All “wetted surfaces” shall be lead free (<.25% Pb) in conformance with the 1/4/14 federal law
- Shall have a variable frequency drive (VFD) with a pressure transducer, pressure gauge, and relief valve
- Each system shall have a properly sized air charged pneumatic tank
- Pump shall be connected to a separate and independent disconnect box [supplied by others]

Variable Frequency Drive (VFD) shall:

- Shall be rated using specified power requirement, efficiency shall be 98% or better at full speed
- All factory preset values and/or last saved data values must remain available to the operator in the event of a complete power outage
- NEMA 1 rated conduit enclosure
- Operate to a program that protects the pump against damaging hydraulic conditions such as:
 - Motor overload, pump overflow surges, loss of prime due to incoming water supply interruption, hunting, overload through frequency/current optimization, hydraulic damage by restricting the pumps to operate beyond their published end of curve
- Automatically restart after an over-current, over-voltage, under-voltage or loss of input signal protective trip
- Have an operator control panel [keypad] for customization of parameters
- Include a feature to upload / download parameters into an external device to be used with another drive or the same drive
- Have a removable non-volatile memory device
- Be capable of accepting individual analog inputs from transducer. All transducer inputs must be wired to the variable frequency drive for continuous scan and comparison function
- Utilize a proportional ladder logic program - integral - derivative control function
- Display the following values:
 - Pump running/standby, pump speed in Hz, user adjustable parameters such as PID set points
 - Motor frequency, motor current, threshold set points for PID error, minimum operating frequency
 - Troubleshooting and diagnostics of faults

Transducer:

- Shall be provided to supply all pressure signals to the variable frequency drive
- Shall be rated for required system pressure and shall be 4-20 mA analog

Centrifugal pump:

- Shall have cast iron casing with 304 stainless steel impellers. (All Stainless steel pump is an available upgrade)
- Shall have a 316 stainless steel shaft sleeve and a replaceable tungsten carbide + HNBR mechanical seal
- Mechanical seal shall be rated to withstand pressure of up to 142 PSI
- Motor shall be totally enclosed fan cooled (TEFC) and manufactured in compliance with CE, RoHS and CSA

Pneumatic expansion tank:

- Shall be rated for use with potable water with an operating pressure of a maximum 125 PSI
- Shall be pre-charged to a pressure of 10 PSI below system operating pressure

Valves and fittings:

- Shall be sized appropriately to allow water velocity not exceeding 10 ft/sec, to minimize cavitation and turbulence
- Check valve shall be spring-loaded and silent

Installation:

- Equipment shall be installed in accordance with applicable local building, electrical and plumbing codes
- Shall be installed indoors (unless otherwise specified) and protected from water spray



Warranty: Provide VFD warranty, for one year from startup, not to exceed 18 months from the date of shipment. Warranty shall include parts, and labor allowance for repair hours.



Performance Features (Drive)

- Ratings:
1 to 5 HP at 200-240 VAC 1-Ph.
1 to 25 HP (ND) at 200-240 VAC 3-Ph.
1 to 25 HP (ND) at 380-480 VAC 3-Ph.
- Overload Capacity:
120% for 60 sec. (Normal Duty)
- Control Methods: V/f Control,
Open Loop Current Vector Control
- DC injection braking, ramp to stop
- Electronic reversing
- Adjustable accel/decel: 0.01 to 6000 seconds
- Controlled speed range:
40:1⁽¹⁾ 100:1⁽²⁾
- Speed Regulation:
± 0.5 to 1% with slip compensation⁽¹⁾
± 0.2%⁽²⁾
- Displacement power factor: 0.98
- Output frequency: 0 to 400 Hz
- Frequency resolution:
0.01 Hz with digital reference
0.06 / 60 Hz with analog reference
- Frequency accuracy:
0.01% with digital command
0.5% with analog command
- Volts / hertz ratio: infinitely adjustable pattern
- DC Injection braking: adjustable amplitude, duration, current limited
- Torque boost: full range, auto
- Power loss ride-thru: 0.5 sec.
- Speed search
- Auto restart
- 3 Critical frequency rejection settings
- Slip Compensation
- Energy Savings Function
- Enhanced PID with loss of feedback function

⁽¹⁾ V/f Mode

⁽²⁾ Open Loop Current Vector Mode

Design Features (Drive)

- Dual microprocessor logic
- Digital keypad operator, 5 digits
- LED status display
- Remote Mount Keypad Capability
- RJ-45 Style Digital Operator Connector
- 7 multifunction digital inputs
- 3 multifunction digital outputs
- Hardwire baseblock (EN954-1 Cat. 3)
- Programmable form C output contact for customer use: 1A at 250 VAC or 30 VDC
- 24 VDC control logic compatible with sourcing or sinking outputs (PNP or NPN)
- Carrier frequency: 15 kHz max; swing PWM
- 2 Remote speed references:
0-10 VDC (20 kohms) or isolated 4-20 mA (250 ohms)
- Signal follower: bias and gain
- 2 programmable open collector outputs
- Analog monitor output:
0-10 VDC proportional to output frequency or output current
- Approx. 400 parameters and monitors
- Digital pulse train input (33 kHz max.)
- Cooling fan controlled by drive run/stop
- RS-422/485 Modbus 115 kbps
- UL recognized electronic overload
- MTBF: 28 years
- NEMA 1 enclosure
- Side-by-Side mounting
- Maintenance monitors

Protective Features (Drive)

- Current limit, stall prevention during accel, decel, and run
- Motor and drive overload
- Over voltage prevention function
- Instantaneous over current
- Short circuit
- Under voltage
- Heatsink overheat
- Ground fault protection
- Over/under torque
- Short circuit current rating: 30kA rms sym.

Pump Control Features

- Operator keypad with intuitive pump language
- Hand-Off-Auto
- Programmable pump process set point
- Pump start level and start time
- Sleep protection
- Simplex, duplex and triplex control
- Automatic system restart
- No flow detection
- Low and high feedback set points
- Pre-charge low level control
- Thrust bearing control
- Automatic system stabilization
- Motor condensation pre-heat function

Pump Protective Features

- Dry well
- Air in system
- Blocked impeller
- Pump over cycling
- No flow protection
- Loss of prime
- Transducer loss
- Over torque

Pump Alarms and Messages

- Low feedback
- High feedback
- Low level
- Low water
- Pump over cycling
- No flow detection
- Loss of prime
- Pump fault
- Motor thermostat
- Pre-charge mode
- Thrust bearing active
- Start mode active
- Sleep mode active

MULTISTAGE CENTRIFUGAL PUMP

WALRUS

MULTISTAGE CENTRIFUGAL PUMP

TPH2T/4T/8T/12T

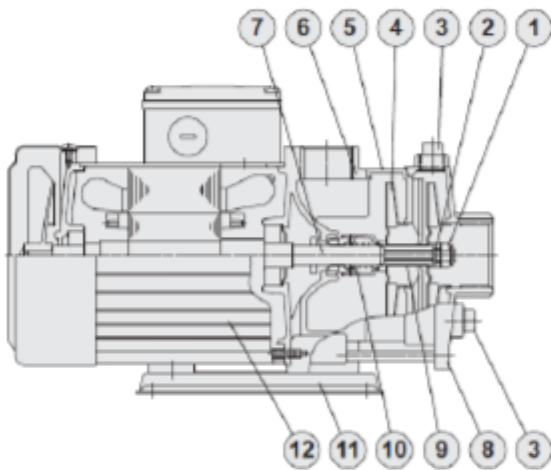

Motors:

- The pump is coupled with (TEFC) Totally Enclosed Fan Cooled, squirrel-cage motor.
- Nominal speed: 3500 rpm at 60Hz
- Protection class: IP54
- Insulation class: F

Pumps:

- Horizontal multi-stage centrifugal pump
- Non self-priming
- close coupled design
- Impellers mounted on extended motor shaft.

Materials

No.	Part name	Material		
		Standard	S series	N series
1	Lock Nut	SUS 316	SUS 316	SUS 316
2	Sleeve(Shaft End)	SUS 304	SUS 304	SUS 316
3	Water Plug	FC 20	SUS 304	SUS 316
4	Impeller	SUS 304	SUS 304	SUS 316
5	Intermediate Chamber	SUS 304	SUS 304	SUS 316
6	Pump Casing	FC 20	SUS 304	SUS 316
7	Shaft	SUS 304	SUS 304	SUS 316
8	Suction Chamber	FC 20	SUS 304	SUS 316
9	Sleeve	SUS 304	SUS 304	SUS 316
10	Mechanical Seal	Tungsten carbide + HNBR		
11	Mounted Base	Coating Steel	SUS 316	
12	Motor Shell	Aluminum alloy		

SUS 304 may be replaced by SUS316 depended on stock availability.

Operating Limits:

- Ambient temperature: Max. 104°F (40°C)
- Liquid temperature range: 32°F (0°C) to 194°F (90°C)
- Operating pressure: Max. 142 psi
- Inlet pressure: Max 85 psi

Suitable Liquids:

- Clean or other non-corrosive liquids



PNEUMATIC EXPANSION TANK SPECIFICATIONS

Models: PLT-5, PLT-12, PLT-20

Air Side Pre-pressure (psi) (bar)	Water Side Volume at 150psi (10.3 bar) (gallons)		
	PLT-5	PLT-12	PLT-20
20 (1.4)	1.48	3.42	7.102
40 (2.8)	1.26	2.88	5.882
60 (4.1)	1.0	2.49	4.705
80 (5.5)	.80	1.85	4.009

Description	PLT-5 Order No. 0067370	PLT-12 Order No. 0067371	PLT-20 Order No. 0067372
Max. Pressure - psi	150	150	150
Max. Temp. - °F	200	200	200
Tank Volume - gal.	2.1	4.5	8.5
Tank Acceptance - gal.	1.26	2.8	3.4
Air Pre-charge - psi	20	20	20
Connections Size - in.	¾ male	¾ male	¾ male
Diameter - in.	8	10.5	12½
Length - in.	11	13.5	19¾
Weight - lbs.	5.5	10	15



Certified to ANSI/NSF 61
(73°F/23°C)



Listed by IAPMO

CALIFORNIA PROPOSITION 65 WARNING
WARNING: This product contains chemicals known to the State of California to cause cancer and birth defects or other reproductive harm. (California law requires this warning to be given to customers in the State of California.)
For more information: www.watts.com/prop65

Disclaimer: The manufacturer of this tank does not accept any liability or other responsibility for personal injury or property damage resulting from improper use, installation or operation of this tank or the system of which it is a part.

Notice: The expansion tank, piping and your connections may in time leak. Select a location to install the expansion tank where a water leak will not damage the surrounding area. The manufacturer is not responsible for any water damage in connection with this expansion tank.

Limited Warranty: Watts Regulator Co. (the "Company") warrants each product to be free from defects in material and workmanship under normal usage for a period of one year from the date of original shipment. In the event of such defects within the warranty period, the Company will, at its option, replace or recondition the product without charge.

THE WARRANTY SET FORTH HEREIN IS GIVEN EXPRESSLY AND IS THE ONLY WARRANTY GIVEN BY THE COMPANY WITH RESPECT TO THE PRODUCT. THE COMPANY MAKES NO OTHER WARRANTIES, EXPRESS OR IMPLIED. THE COMPANY HEREBY SPECIFICALLY DISCLAIMS ALL OTHER WARRANTIES, EXPRESS OR IMPLIED, INCLUDING BUT NOT LIMITED TO THE IMPLIED WARRANTIES OF MERCHANTABILITY AND FITNESS FOR A PARTICULAR PURPOSE.

The remedy described in the first paragraph of this warranty shall constitute the sole and exclusive remedy for breach of warranty, and the Company shall not be responsible for any incidental, special or consequential damages, including without limitation, lost profits or the cost of repairing or replacing other property which is damaged if this product does not work properly, other costs resulting from labor charges, delays, vandalism, negligence, fouling caused by foreign material, damage from adverse water conditions, chemical, or any other circumstances over which the Company has no control. This warranty shall be invalidated by any abuse, misuse, misapplication, improper installation or improper maintenance or alteration of the product.

Some States do not allow limitations on how long an implied warranty lasts, and some States do not allow the exclusion or limitation of incidental or consequential damages. Therefore the above limitations may not apply to you. This Limited Warranty gives you specific legal rights, and you may have other rights that vary from State to State. You should consult applicable state laws to determine your rights. **SO FAR AS IS CONSISTENT WITH APPLICABLE STATE LAW, ANY IMPLIED WARRANTIES THAT MAY NOT BE DISCLAIMED, INCLUDING THE IMPLIED WARRANTIES OF MERCHANTABILITY AND FITNESS FOR A PARTICULAR PURPOSE, ARE LIMITED IN DURATION TO ONE YEAR FROM THE DATE OF ORIGINAL SHIPMENT.**





Booster Pump Systems

Three Year Limited Warranty

This warranty applies to booster pump systems built by Towle Whitney LLC, and shall:

- Exist 36 months from the date of shipment.
- Be in effect only after installation photographs are received by Towle Whitney LLC.

Towle Whitney LLC liability under this warranty shall be limited to the repair or replacement of any part or parts found to be defective (material or workmanship) within the warranty period. Towle Whitney LLC shall determine whether the part needs to be returned, or field scrapped. The warranty excludes:

- Any water damage or consequential damage.
- Transducers & Pump Seals.
- Debris in water causing damage to pump internal parts.
- Systems not installed in accordance with Installation and Maintenance Instructions.
- Labor, transportation, and related costs incurred by the customer.
- Misuse, negligence, inappropriate chemicals or additives in water.
- Inadequate protection from freezing.
- Lightning, high voltage spikes, accidents, floods, or acts of God.
- Re-Installation costs of repaired or replacement equipment.
- Re-Imbursement for the loss caused by interruption of service.
- Adjusting drive parameters without consulting Towle Whitney.

This warranty applies to all states and territories of the United States and Canada only. There are no express or implied warranties, including merchantability or fitness for a particular purpose, which extend beyond those warranties described or referred to above.

Some jurisdictions do not allow the exclusion or limitation of incidental or consequential damages and some jurisdictions do not allow limit actions on how long implied warranties may last. Therefore, the above limitations or exclusions may not apply. This warranty gives you specific legal rights and you may also have other rights which vary from jurisdiction to jurisdiction.