



Project: _____
Location: _____
Mark: _____
Engineer: _____

Base Model

Optional Equipment

TW2975T-200R-75

-

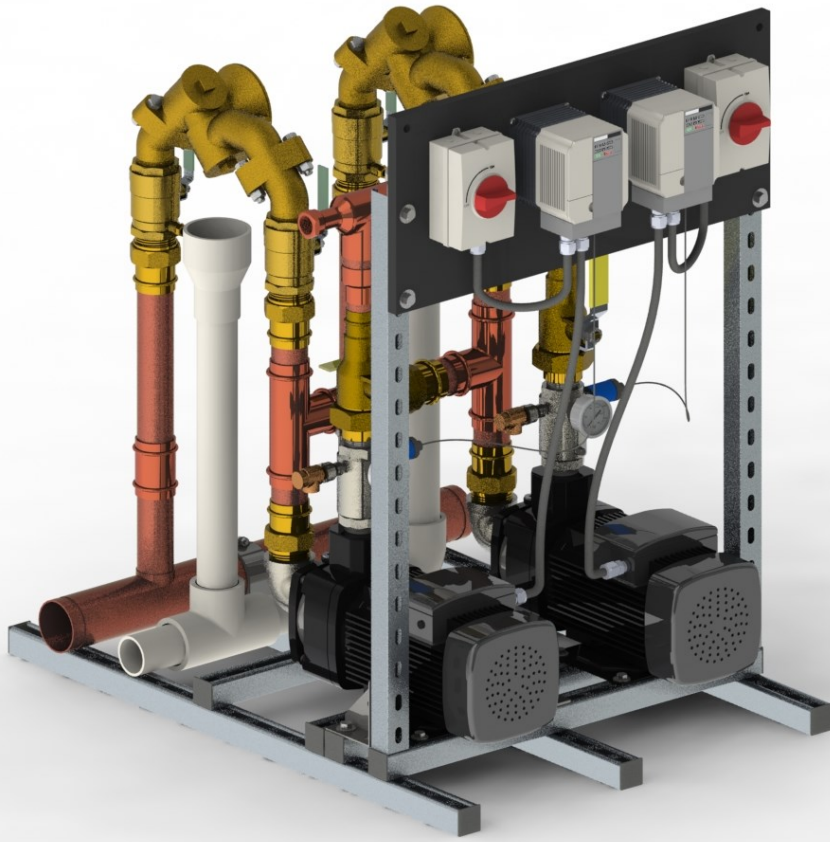

US. Pat. No. 11,268,265



Model:

TW2975T-200R-75 DUPLEX

The TW2975T-200R-75 Duplex GEN5 PLATFORM is equipped with a VFD controlled booster pump system, backflow prevention system, and a DWV piping system.

The standard GEN5 PLATFORM can be upgraded to include optional equipment, such as 188-bypass, flood control, meter test tee's, RP strainers, low pressure port, and copper DWV.

Instead of large diameter (3"/ 4") backflow preventer(s) at the meter, each pump's suction line is protected with a 2" Reduced Pressure Zone (RP) backflow preventer.

Networked VFD's eliminate the need for both the UL508 panel and Programmable Logic Controller (PLC).

System is built to fit through a 30" doorway.

Technical Specifications:

Pumps: Grundfos CM15-3

Horse Power: 8 HP per pump

VF Drives: Yaskawa iQ Micro

Flow Rate: 200 GPM

50/50 Split: 100 GPM per pump

Boost: 75 PSI (174')

Manifolds: 3" (Reversible in field)

RP: 2"

Tank: 32 Gallon

Frame Size: 29" W x 42" H x 45" D

Weight (appr): 350 lbs

Power Options: Two independent circuits required
208/1, 208/3, 480/3

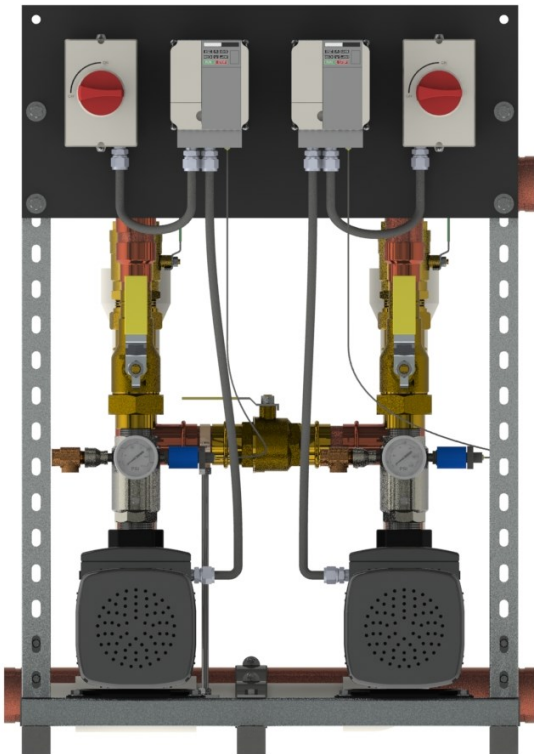

US. Pat. No. 11,268,265

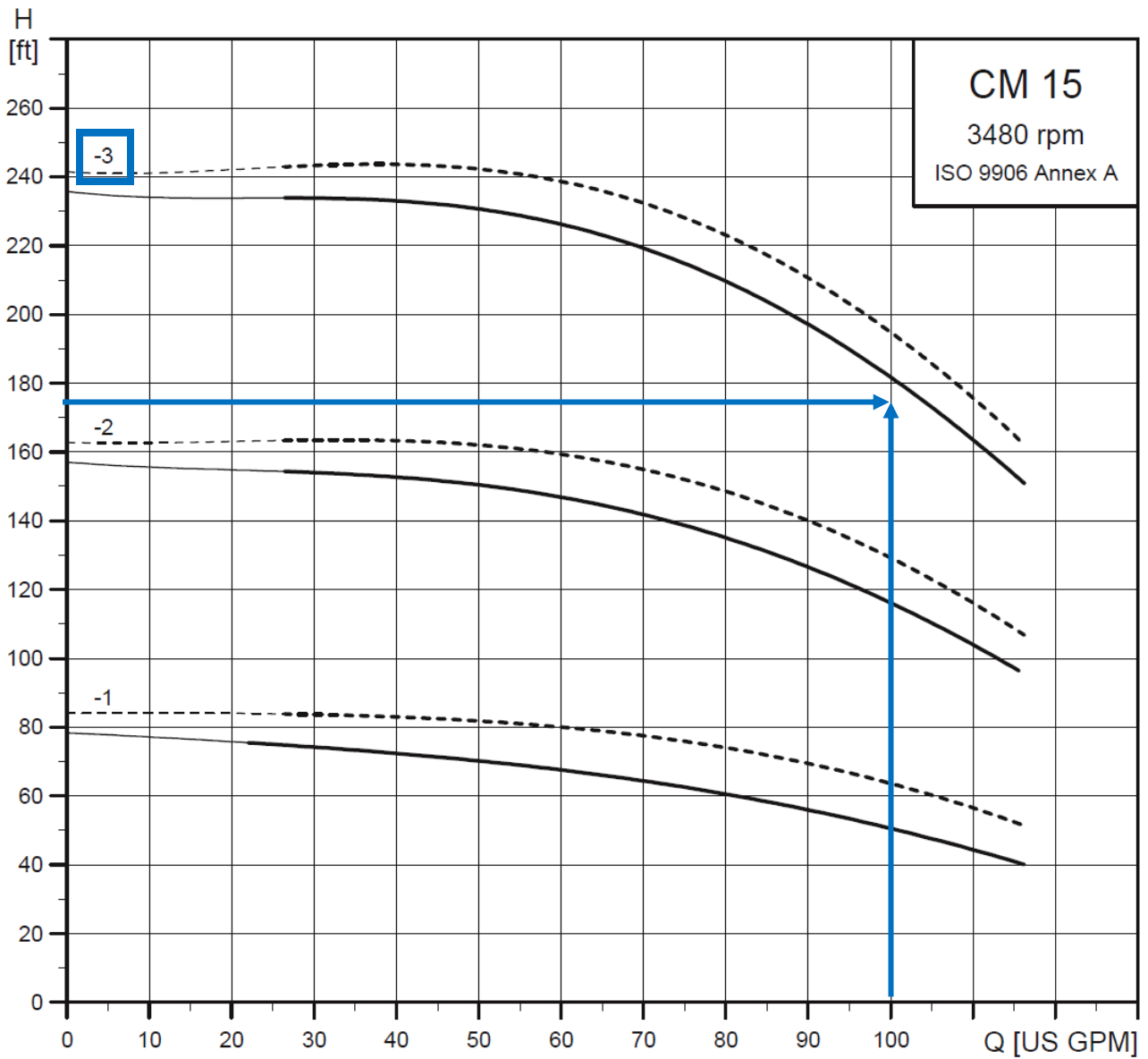

US. Pat. No. 11,268,265

CM(E) I and CM(E) G

(I = AISI 304 / EN 1.4301 and G = AISI 316 / EN 1.4401)

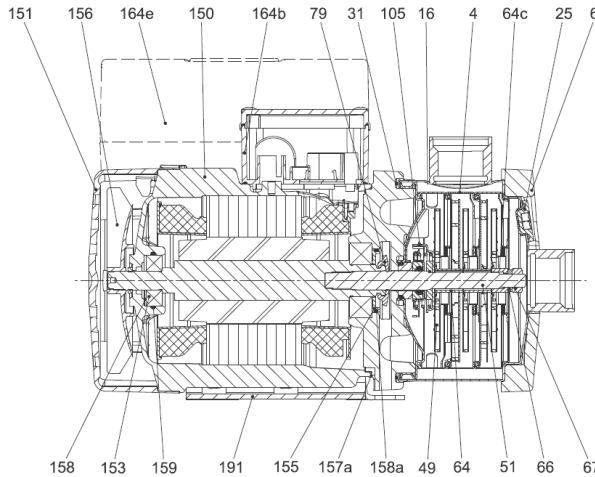

TM04 3722 3689

Fig. 12 CM(E) 1-3 with ML(E) 71 motor

Components

Pos.	Component	Pos.	Component	Pos.	Component
4	Chamber	64c	Clamp	155	Bearing cover plate
6	Flange	66	Washer (NORD-LOCK®)	156	Fan
16	Sleeve	67	Nut	157a	Gasket
25	Plug	79	Diverting disc	158	Corrugated spring
31	O-ring	105	Shaft seal	158a	O-ring
49	Impeller	150	Stator housing	159	O-ring
51	Pump shaft	151	Fan cover	164b, 164e	Terminal box
64	Spacing pipe	153	Ball bearing	191	Base plate

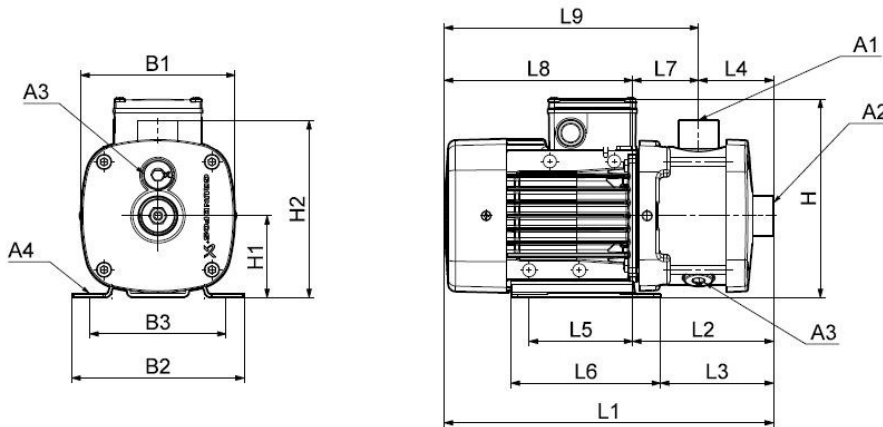

TM04 2246 2208

Dimensions

3 x 208-230 V / 440-480 V, 60 Hz (supply voltage E)
 3 x 575 V, 60 Hz (supply voltage H)

Pump type	Frame size	P ₂ [Hp]	NPT			Rp	Dimensions [in (mm)]														
			A1	A2	A3		A4	B1	B2	B3	H	H1	H2	L1	L2	L3	L4	L5	L6	L7	L8
CM 15-1	90	3.4	2"	2"	3/8"	0.39 (10)	7.09 (180)	7.84 (199)	6.30 (160)	8.23 (210)	3.94 (100)	8.58 (218)	17.72 (450)	8.62 (219)	8.03 (204)	4.13 (105)	5.52 (140)	6.69 (170)	4.49 (114)	9.13 (232)	13.58 (345)
CM 15-2	100	5.4	2"	2"	3/8"	0.39 (10)	7.80 (198)	7.84 (199)	6.30 (160)	8.66 (220)	3.94 (100)	8.58 (218)	19.96 (507)	9.25 (235)	8.66 (220)	4.13 (105)	5.52 (140)	6.69 (170)	5.12 (130)	10.71 (272)	15.83 (402)
CM 15-3	112	8.0	2"	2"	3/8"	0.47 (12)	8.66 (220)	8.98 (228)	7.48 (190)	9.69 (246)	4.91 (112)	9.06 (230)	22.01 (559)	10.12 (257)	9.49 (241)	4.13 (105)	5.52 (140)	6.77 (172)	5.98 (152)	11.89 (302)	17.87 (454)

US. Pat. No. 11,268,265

Pos.	Description	Material	Pump material version					
			CM(E) A Cast iron (ASTM A48 CL30/ EN-GJL-200)		CM(E) I Stainless steel (AISI 304 / EN 1.4301)		CM(E) G Stainless steel (AISI 316) / EN 1.4401	
			DIN W.-Nr.	ISO/AISI/AS TM	DIN W.-Nr.	ISO/AISI/AS TM	DIN W.-Nr.	ISO/AISI/AS TM
Motor parts								
156b	Motor flange	Cast iron						
150	Stator housing	Silumin (Alu)						
151	Fan cover	Composite PBT/PC						
153	Ball bearing							
156	Fan	Composite PA 66 30 % GF						
158	Corrugated spring	Steel						
164b	Terminal box, MG	Composite PC/ASA or silumin (Alu)						
164e	Terminal box, MGE							
191	Base plate	Steel, cataphoresis-treated	1.0330.3	ASTM A366 / A611-C1	1.0330.3	ASTM A366 / A611-C1		
		Steel, powder-coated, 60 to 120 µ, NCS 7005					1.0330.3	ASTM A366 / A611-C1
79	Diverting disc	Silicone fluid (LSR)						
155	Bearing cover plate	PPS						
Pump parts								
105	Shaft seal, steel parts	Stainless steel	1.4301/1.440 1 ¹⁾	AISI 304/ AISI 316 ¹⁾	1.4301/1.440 1 ¹⁾	AISI 304/ AISI 316 ¹⁾	1.4401	AISI 316
	Shaft seal, seal faces	SiC/SiC or Al ₂ O ₃ /carbon						
51	Pump shaft	Stainless steel	1.4057	AISI 431	1.4301/1.440 1 ¹⁾	AISI 304/ AISI 316 ¹⁾	1.4401	AISI 316
11 31 ¹⁾ 158a 159	O-rings	EPDM, FKM or FFKM						
157a ¹⁾	Gasket	Paper						
139b ²⁾	Gasket	Aramide fibers (nbr)						
2 ²⁾	Discharge part	Cast iron						
6 ²⁾	Inlet part	Cast iron						
4	Chamber	Stainless steel	1.4301/1.440 1 ¹⁾	AISI 304/ AISI 316 ¹⁾	1.4301/1.440 1 ¹⁾	AISI 304/ AISI 316 ¹⁾	1.4401	AISI 316
25	Plug	Stainless steel	1.4401	AISI 316L	1.4401	AISI 316L	1.4401	AISI 316L
49	Impeller	Stainless steel	1.4301/1.440 1 ¹⁾	AISI 304/ AISI 316 ¹⁾	1.4301/1.440 1 ¹⁾	AISI 304/ AISI 316 ¹⁾	1.4401	AISI 316
64	Spacing pipe	Stainless steel	1.4401	AISI 316	1.4401	AISI 316	1.4401	AISI 316
64c	Clamp	Stainless steel	STX2000 ³⁾		STX2000 ³⁾		STX2000 ³⁾	
6 ¹⁾	Flange	Cast iron						
16	Sleeve	Stainless steel			1.4301/1.440 1 ¹⁾	AISI 304/ AISI 316 ¹⁾	1.4401	AISI 316
67	Nut	Stainless steel A4						
66	Washer (NORD-LOCK®)	Steel	1.4547 ⁴⁾		1.4547 ⁴⁾		1.4547 ⁴⁾	

^{*)} On request.

¹⁾ Only in CM(E)-I/G pumps.

US. Pat. No. 11,268,265

Electrical

Yaskawa VFD UL 508C Power Conversion
CSA 22.2 Industrial Controls



RoHS

Lovato Shut-off NEMA4



RoHS

Pumps

Grundfos CM(I) SS Series NSF 61
Goulds 125MS Series NSF 61
Goulds 3656 Series NSF 61
Walrus TPH Series NSF 362

Major Plumbing Components

Bluefin BVT200 Ball Valves NSF 61
Zurn/Wilkins RP: 975XL2 NSF 61
Watts/Febco RP: LF825YA NSF 61
Watts LF777SM3 Strainer NSF 61
Flomatic 8SSBVFD Checks NSF 61
Bonomi Check 1000012 NSF 61
Bonomi SS 8E067-012 valve NSF 61
Victaulic 607 "E" Coupling NSF 61
Victaulic 660 Cap NSF 61
Flexcon H2P25 Tank NSF 61
Amtrol Pro-Line Tanks NSF 61
Manifolds / piping Type L Copper
Fittings Copper
Discharge Riser Copper
- Pressure Relief valve: SS
- SS 4-20mA Transducer: SS
- Pressure Gauges: CA AB1953

Sealants

Rectorseal Nokorode Flux NSF 61
Worthington SILVER Solder NSF 61
LocTite 567 Thread Sealant NSF 61
Gasola Thread Sealant NSF 61

US. Pat. No. 11,268,265

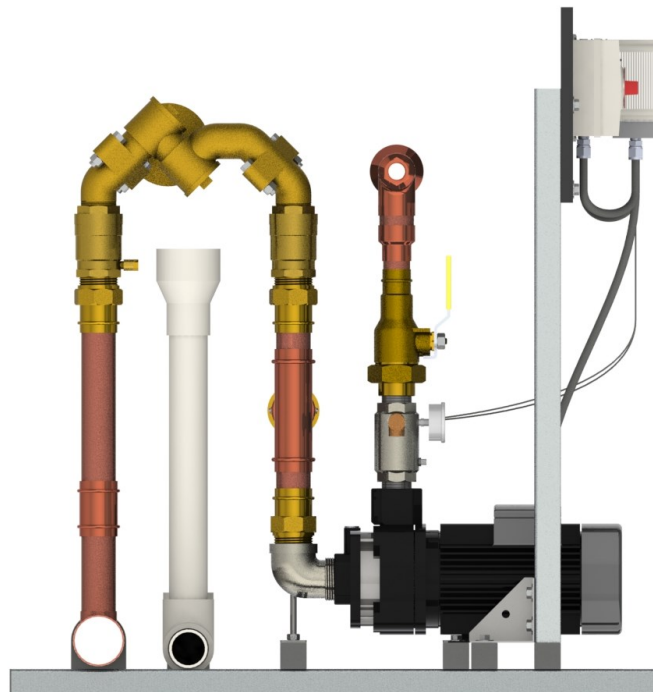
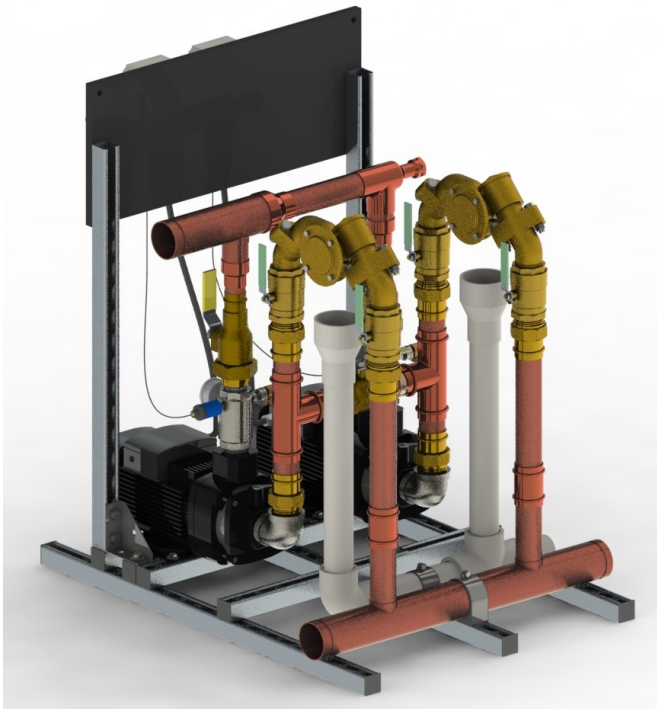

US. Pat. No. 11,268,265

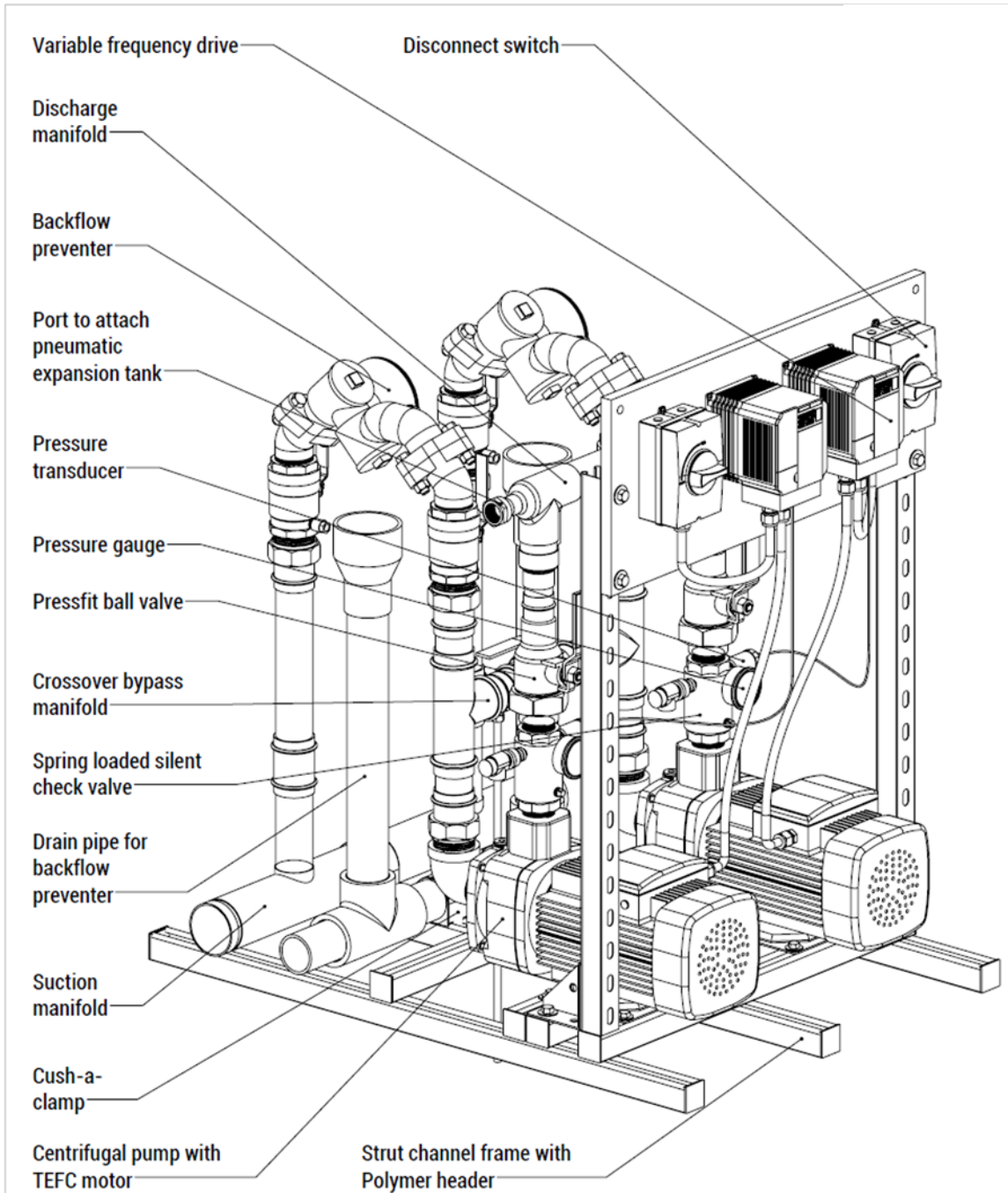

PROPRIETARY AND CONFIDENTIAL
THE INFORMATION CONTAINED IN THIS DRAWING IS THE SOLE PROPERTY OF TOWLE WHITNEY LLC. ANY REPRODUCTION IN PART OR AS A WHOLE WITHOUT THE WRITTEN PERMISSION OF TOWLE WHITNEY LLC IS PROHIBITED.

DIMENSIONS ARE SUBJECT TO CHANGE
DO NOT USE FOR CONSTRUCTION
UNLESS OTHERWISE SPECIFIED
DIMENSIONS ARE IN INCHES

DO NOT SCALE DRAWING

NAME	DATE
DRAWN: VID	9/10/23
CHECKED: DW	9/10/23
COMMENTS:	

TOWLE WHITNEY LLC	
Duplex Variable Speed Booster System with Backflow Preventers	
SIZE: A	DWG. NO. 2023-09-10-A
SCALE: 1:16	WEIGHT: SHEET 1 OF 1

US. Pat. No. 11,268,265

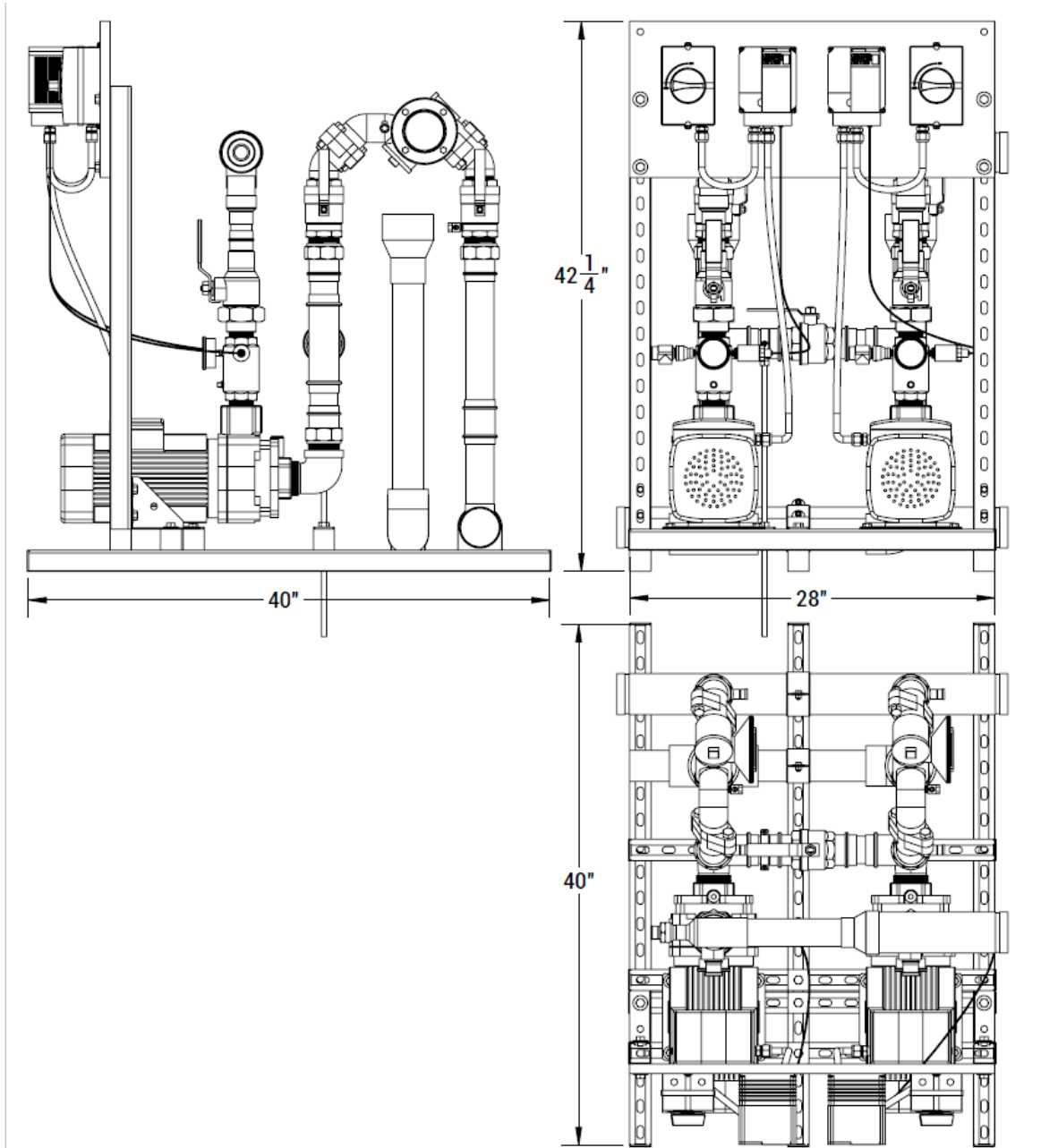

PROPRIETARY AND CONFIDENTIAL
THE INFORMATION CONTAINED IN THIS DRAWING IS THE SOLE PROPERTY OF TOWLE WHITNEY LLC. ANY REPRODUCTION IN PART OR AS A WHOLE WITHOUT THE WRITTEN PERMISSION OF TOWLE WHITNEY LLC IS PROHIBITED.

DIMENSIONS ARE SUBJECT TO CHANGE
DO NOT USE FOR CONSTRUCTION
UNLESS OTHERWISE SPECIFIED
DIMENSIONS ARE IN INCHES

DO NOT SCALE DRAWING

	NAME	DATE
DRAWN	VID	9/10/23
CHECKED	DW	9/10/23
COMMENTS:		

TOWLE WHITNEY LLC
Duplex Variable Speed Booster System with Backflow Preventers

SIZE	DWG. NO.	REV.
A	2023-09-10-B	
SCALE:1:16	WEIGHT:	SHEET 1 OF 1

US. Pat. No. 11,268,265

Assembled Units:

- All “wetted surfaces” shall be lead free (<.25% Pb) in conformance with the 1/4/14 federal law
- Each pump shall include an independent variable frequency drive (VFD) and disconnect switch.
- Each pump shall include a Reduced Pressure Zone Assembly (RP) backflow preventer and DWV system.

Variable frequency drive:

- Will ALTERNATE the lead pump every 24 hours (field adjustable) of run time. The lag pump shall be in standby
- Shall have hands-off automatic (HOA) capability
- Rated to operate using specified power requirement. The drive efficiency shall be 98% or better
- Have UL approval with all factory installed options and preset values and/or last saved data values will remain available to the operator after power outage
- Shall have at least NEMA 1 rated conduit enclosure
- The program will protect the pumps against damaging hydraulic conditions such as:
 - Motor overload, Pump overflow surges, Loss of prime due to incoming water supply interruption, Hunting
 - Protection from overload through frequency/current optimization
 - Protection from hydraulic damage by restricting the pumps to operate beyond their published end of curve
- Shall have the ability to automatically restart after an over-current, over-voltage, under-voltage or loss of input signal
- Shall have an operator control panel [keypad] for customization of parameters
- Shall include a feature to upload/download parameters into an external device to be used with another drive or the same drive
- Shall be capable of accepting individual analog inputs from transducer. All transducer inputs must be wired to the variable frequency drive for continuous scan and comparison function
- Ladder logic program shall utilize a proportional - integral - derivative control function
- Shall display the following values:
Pump running/standby, Pump speed in Hz, User adjustable parameters such as PID set points, Motor frequency, Motor current, Threshold set points for PID error, Min operating frequency, Troubleshooting and diagnostics of faults

Transducer:

- The transducer shall be rated for required system pressure and shall be 4-20 mA analog
- Separate transducers shall be supplied for each variable frequency drive to ensure redundancy

Centrifugal pump:

- Refer to Pump specs on Shall have a stainless steel casing and stainless steel impellers.
- Shall have a 316 stainless steel shaft sleeve. Mechanical seal shall be rated to withstand pressure of up to 142 PSI
- Motor shall be to totally enclosed fan cooled (TEFC), and manufactured in compliance with CE, RoHS and CSA

Pneumatic expansion tank:

- Pneumatic expansion tank shall be rated for use with potable water with an operating pressure of a maximum 150 PSI
- Pre-charged to a pressure of 10 PSI below system operating pressure for system to run properly

US. Pat. No. 11,268,265

Backflow Prevention:

- Each pump shall be supplied with a:
 - Reduced Pressure Zone (RP) Assembly backflow preventer:
 - Watts/Febco LF825YA
 - Zurn/Wilkins 975XL2SEU
 - DWV piping
- Each RP shall be capable of being tested independently, regardless of which pump is running.

Manifolds, valves and fittings:

- Suction Manifold shall be dual ended, with one end capped.
- Discharge Manifold should be specified either right or left (field adjustable if needed).
- To simplify ProPress or solder installations,
 - *Groove x Plain-end* spool pieces supplied for suction and discharge manifolds.
 - to connect to pipe, spool pieces included.
- Crossover Bypass Manifold (CBM) shall allow water supply to either pump. CBM ball valve is normally open.
- Shall be sized appropriately to allow water velocity not exceeding 10 ft/sec, to minimize cavitation and turbulence
- For isolation and maintenance, each pump shall have ball valves and grooved couplings.

Installation:

- Equipment shall be installed in accordance with applicable local building, electrical and plumbing codes
- Shall be installed indoors (unless otherwise specified) and protected from water spray

Optional Equipment / Suffixes (consult individual pages):

- 188-bypass shall be designated either:
 - right (-BR)
 - left (-BL)
- Type "L" copper DWV piping (-C)
- Flood Control (-FC)
- NEMA4X VFD (-N4)
- Low Pressure Port (-LPP)
- RP strainers and isolation ball valves (-S)
- Meter Test TEE (-TT)

US. Pat. No. 11,268,265

LEAD FREE*

Series LF825YA

Angle Pattern Reduced Pressure Zone Assemblies

Size: 3/4" - 2" (20 - 50mm)**

The FEBCO Series LF825YA Reduced Pressure Zone Assemblies are used to protect against toxic fluids in water services to industrial plants, hospitals, morgues, mortuaries, and chemical plants. They are also used in irrigation systems, boiler feeds, water lines and other installations requiring the highest level of mechanical protection. The LF825YA features Lead Free* construction to comply with Lead Free* installation requirements. End connection - NPT ANSI/ASME B1.20.1

Features

- Installation versatility simplifies new and retrofit installations.
- Eliminates pipe elbows, nipples and unions from the installation.
- Reduces installation time, labor costs and materials.
- Compact design simplifies retrofit.
- Integral flanged union connections allow assembly to be removed from the line for freeze protection or maintenance without the danger of spool substitution.
- Approved by the Foundation for Cross-Connection Control and Hydraulic Research at the University of Southern California.
- Modular relief valve and check valve internal components for ease of maintenance.
- Smaller, less costly protective enclosures can be used to provide freeze and vandalism protection due to compact size of valve.
- Field tested design for reliability and performance.
- Replaceable seat rings for longer valve life.
- Low head loss for optimum performance.

Operation

In a flow condition, the check valves are open with the pressure between the checks, called the zone, being maintained at least 5psi (34 kPa) lower than the inlet pressure. The relief valve is held closed by the pressure differential.

Should abnormal conditions arise under no flow or reversal of flow, the differential relief valve will open and discharge to maintain the zone at least 2psi (14 kPa) lower than the supply.

When normal flow resumes, the zone's differential pressure will return and the relief valve will close.

Approvals - Standards

- Approved by the Foundation for Cross-Connection Control and Hydraulic Research at the University of Southern California.
- AWWA C511 Conformance



FEBCO product specifications in U.S. customary units and metric are approximate and are provided for reference only. For precise measurements, please contact FEBCO Technical Service. FEBCO reserves the right to change or modify product design, construction, specifications, or materials without prior notice and without incurring any obligation to make such changes and modifications on FEBCO products previously or subsequently sold.



Specifications

The reduced pressure zone assemblies shall consist of two independently operating, spring loaded, "Y" pattern check valves and one hydraulically dependent differential relief valve. Should the differential between the upstream and the zone of the unit drop to 2psi (14 kPa), the differential relief valve shall open and maintain the proper differential.

Mainline valve body and caps including relief valve body and cover shall be Lead Free* cast copper silicon alloy. Check valve moving members shall be center stem guided. Relief valve shall have a removable seat ring. Check valve and relief valve components shall be constructed so they may be serviced without removing the valve body from the line. All seat discs shall be reversible.

The assembly shall include flanged unions located between the mainline valve body and the ball valve shutoffs to allow for field removal for freeze protection or maintenance without danger of spool replacement. The Lead Free* Angle Pattern Reduced Pressure Zone Assemblies shall comply with state codes and standards, where applicable, requiring reduced lead content.

The assembly shall be rated to 175psi (12.1 bar) water working pressure and water temperature range from 32°F to 140°F (0°C - 60°C). The assembly shall meet the requirements of the USC Foundation of Cross-connection Control and Hydraulic Research, Eighth Edition.

The assembly shall be a FEBCO Series LF825YA or prior approved equal.

Materials

- Main valve body: Lead Free* Cast Copper Silicon Alloy
- Relief valve body: Lead Free* Cast Copper Silicon Alloy
- Elastomers: Nitrile Seat Discs
- Diaphragms: Nitrile, fabric reinforced
- Springs: Stainless Steel

Pressure - Temperature

- Maximum working pressure: 175psi (12.1 bar)
- Hydrostatic test pressure: 350psi (24.1 bar)
- Temperature range: 32°F to 140°F (0°C to 60°C)

* The wetted surface of this product contacted by consumable water contains less than 0.25% of lead by weight.

** Metric Dimensions are nominal pipe diameter. This product is produced with NPT threaded end connections.



A WATTS Brand

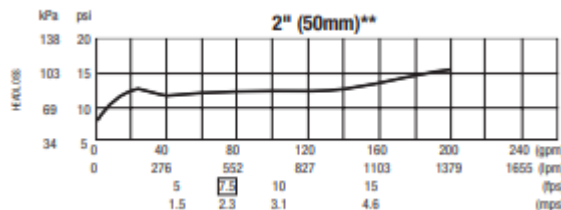

U.S. Pat. No. 11,268,265



Warranty: Provide VFD warranty, for one year from startup, not to exceed 18 months from the date of shipment. Warranty shall include parts, and labor allowance for repair hours.



Performance Features (Drive)

- Ratings:
1 to 5 HP at 200-240 VAC 1-Ph.
1 to 25 HP (ND) at 200-240 VAC 3-Ph.
1 to 25 HP (ND) at 380-480 VAC 3-Ph.
- Overload Capacity:
120% for 60 sec. (Normal Duty)
- Control Methods: V/f Control,
Open Loop Current Vector Control
- DC injection braking, ramp to stop
- Electronic reversing
- Adjustable accel/decel: 0.01 to 6000 seconds
- Controlled speed range:
40:1⁽¹⁾ 100:1⁽²⁾
- Speed Regulation:
± 0.5 to 1% with slip compensation⁽¹⁾
± 0.2%⁽²⁾
- Displacement power factor: 0.98
- Output frequency: 0 to 400 Hz
- Frequency resolution:
0.01 Hz with digital reference
0.06 / 60 Hz with analog reference
- Frequency accuracy:
0.01% with digital command
0.5% with analog command
- Volts / hertz ratio: infinitely adjustable pattern
- DC Injection braking: adjustable amplitude, duration, current limited
- Torque boost: full range, auto
- Power loss ride-thru: 0.5 sec.
- Speed search
- Auto restart
- 3 Critical frequency rejection settings
- Slip Compensation
- Energy Savings Function
- Enhanced PID with loss of feedback function

⁽¹⁾ V/f Mode

⁽²⁾ Open Loop Current Vector Mode

Design Features (Drive)

- Dual microprocessor logic
- Digital keypad operator, 5 digits
- LED status display
- Remote Mount Keypad Capability
- RJ-45 Style Digital Operator Connector
- 7 multifunction digital inputs
- 3 multifunction digital outputs
- Hardwire baseblock (EN954-1 Cat. 3)
- Programmable form C output contact for customer use: 1A at 250 VAC or 30 VDC
- 24 VDC control logic compatible with sourcing or sinking outputs (PNP or NPN)
- Carrier frequency: 15 kHz max; swing PWM
- 2 Remote speed references:
0-10 VDC (20 kohms) or isolated 4-20 mA (250 ohms)
- Signal follower: bias and gain
- 2 programmable open collector outputs
- Analog monitor output:
0-10 VDC proportional to output frequency or output current
- Approx. 400 parameters and monitors
- Digital pulse train input (33 kHz max.)
- Cooling fan controlled by drive run/stop
- RS-422/485 Modbus 115 kbps
- UL recognized electronic overload
- MTBF: 28 years
- NEMA 1 enclosure
- Side-by-Side mounting
- Maintenance monitors

Protective Features (Drive)

- Current limit, stall prevention during accel, decel, and run
- Motor and drive overload
- Over voltage prevention function
- Instantaneous over current
- Short circuit
- Under voltage
- Heatsink overheat
- Ground fault protection
- Over/under torque
- Short circuit current rating: 30kA rms sym.

Pump Control Features

- Operator keypad with intuitive pump language
- Hand-Off-Auto
- Programmable pump process set point
- Pump start level and start time
- Sleep protection
- Simplex, duplex and triplex control
- Automatic system restart
- No flow detection
- Low and high feedback set points
- Pre-charge low level control
- Thrust bearing control
- Automatic system stabilization
- Motor condensation pre-heat function

Pump Protective Features

- Dry well
- Air in system
- Blocked impeller
- Pump over cycling
- No flow protection
- Loss of prime
- Transducer loss
- Over torque

Pump Alarms and Messages

- Low feedback
- High feedback
- Low level
- Low water
- Pump over cycling
- No flow detection
- Loss of prime
- Pump fault
- Motor thermostat
- Pre-charge mode
- Thrust bearing active
- Start mode active
- Sleep mode active

US. Pat. No. 11,268,265



PRO-LINE®
Diaphragm Well Tanks: PL Series

125 PSIG Working Pressure

Construction

Shell	Deep Drawn Steel
Diaphragm	Butyl
Liner	Polypropylene
System Connection	304L Stainless Steel
Finish	Tan
Water Circulator	Turbulator™
Air Valve	Projection Welded
Factory Precharge	38 PSIG (2.6 bar)

Application

- Controls pump cycling in residential well water systems.

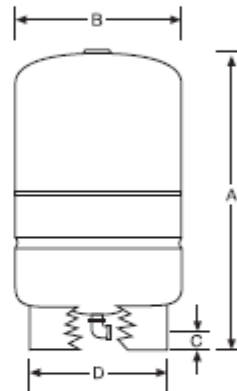

Performance

Maximum Operating Temperature	200°F (93°C)
Maximum Working Pressure	125 PSIG (8.6 bar)
Maximum Relief Valve Setting	100 PSIG (6.9 bar)
Warranty	5 Year

Stand Models

Model	Tank Volume		Max. Accept. Factor	A Tank Height		B Tank Diameter		C Sys. Conn. Centerline		D Stand Diameter		System Conn. (NPTF)	Shipping Weight	
	Gal	Lit		in	mm	in	mm	in	mm	in	mm		in	Lbs
PL-14	14.0	53	0.81	25	635	15	381	1 ¹ / ₂	40	12	304	1	22	10
PL-20	20.0	76	0.57	32	813	15	381	1 ¹ / ₂	40	12	304	1	28	13
PL-26	26.0	98	0.44	39	991	15	381	1 ¹ / ₂	40	12	304	1	34	15
PL-32	32.0	121	0.35	47	1194	15	381	1 ¹ / ₂	40	12	304	1	40	18
PL-34	34.0	129	1.00	30	762	22	559	1 ¹ / ₈	49	20 ¹ / ₂	521	1 ¹ / ₄	50	23
PL-44	44.0	167	0.77	36	914	22	559	1 ¹ / ₈	49	20 ¹ / ₂	521	1 ¹ / ₄	57	26
PL-62	62.0	235	0.55	47	1194	22	559	1 ¹ / ₈	49	20 ¹ / ₂	521	1 ¹ / ₄	75	34
PL-81	81.0	301	0.41	57	1448	22	559	1 ¹ / ₈	49	20 ¹ / ₂	521	1 ¹ / ₄	92	42
PL-86	86.0	326	0.54	47	1194	26	660	2 ¹ / ₈	52	20 ¹ / ₂	521	1 ¹ / ₄	99	45
PL-119	119.0	450	0.39	62	1575	26	660	2 ¹ / ₈	52	20 ¹ / ₂	521	1 ¹ / ₄	133	60

All dimensions and weights are approximate.

US. Pat. No. 11,268,265



Booster Pump Systems

Three Year Limited Warranty

This warranty applies to the GEN5 PLATFORM built by Towle Whitney LLC, and shall:

- Exist 36 months from the date of shipment.
- Be in effect only after installation photographs are received by Towle Whitney LLC.

Towle Whitney LLC liability under this warranty shall be limited to the repair or replacement of any part or parts found to be defective (material or workmanship) within the warranty period. Towle Whitney LLC shall determine whether the part needs to be returned, or field scrapped. The warranty excludes:

- Any water damage or consequential damage.
- Transducers and Pump Seals.
- Backflow prevention repair parts.
- Debris in water causing internal pump damage.
- Systems not installed in accordance with Installation and Maintenance Instructions.
- Labor, transportation, and related costs incurred by the customer.
- Misuse, negligence, inappropriate chemicals or additives in water.
- Inadequate protection from freezing.
- Lightning, high voltage spikes, accidents, floods, or acts of God.
- Re-Installation costs of repaired or replacement equipment.
- Re-Imbursement for the loss caused by interruption of service.
- Adjusting drive parameters without consulting Towle Whitney.

This warranty applies to all states and territories of the United States and Canada only. There are no express or implied warranties, including merchantability or fitness for a particular purpose, which extend beyond those warranties described or referred to above.

Some jurisdictions do not allow the exclusion or limitation of incidental or consequential damages and some jurisdictions do not allow limit actions on how long implied warranties may last. Therefore, the above limitations or exclusions may not apply. This warranty gives you specific legal rights and you may also have other rights which vary from jurisdiction to jurisdiction.

US. Pat. No. 11,268,265