



**TW3018T-330G-35
TRIPLEX VARIABLE SPEED
BOOSTER PUMP SYSTEM**

TW3018T-330G-35 DUPLEX

The *TW3018T-330G-35 Triplex Booster Pump System* is equipped with centrifugal pumps regulated by variable frequency drives that control the pump to maintain constant pressure regardless of varying demand or fluctuating incoming pressure.

VFD drives will ALTERNATE lead pump every 24 hours of run time. Second and third pump will remain on standby.



Lead-Free (Wetted) components:

- Pumps: Cast Iron
- Relief valves: LF Brass
- Pressure Gauges: LF Brass
- Transducers: Stainless Steel
- Check valves: LF Brass
- Ball Valves: LF Brass
- Manifolds: Type L Copper
- Fittings: LF Brass or SS

*All parts shown included
Actual system components may vary
Some assembly required*

* All lead-free brass shall contain <.25% Pb

Technical Specifications:

- Pumps:** Goulds 3BF
- Horse Power:** 3 HP per pump
- VF Drives:** Yaskawa
- Flow Rate:** 330 GPM (110 GPM per pump)
- Boost:** 35 PSI
- Set Pressure:** 65 PSI (unless otherwise specified)
- Manifolds:** 4 Inch
- Tank:** 32 Gallon non-ASME
- Frame:** 43"W X 43"H X 34"D
- Power options:** Three Independent circuits required
208-220V/1PH
208-220V/3PH
360-480V/3PH
Specify when ordering

Performance curve for each pump

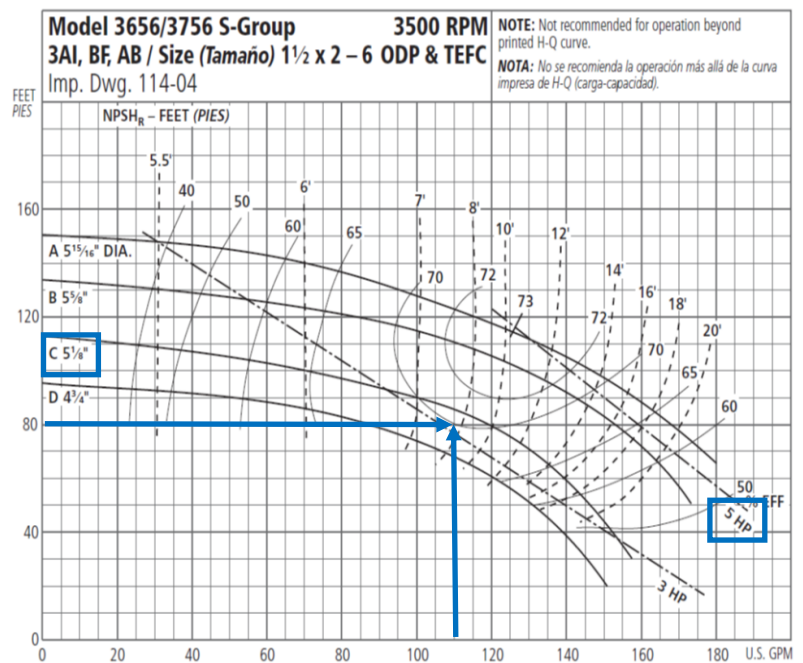

SYSTEM CONFIGURATION

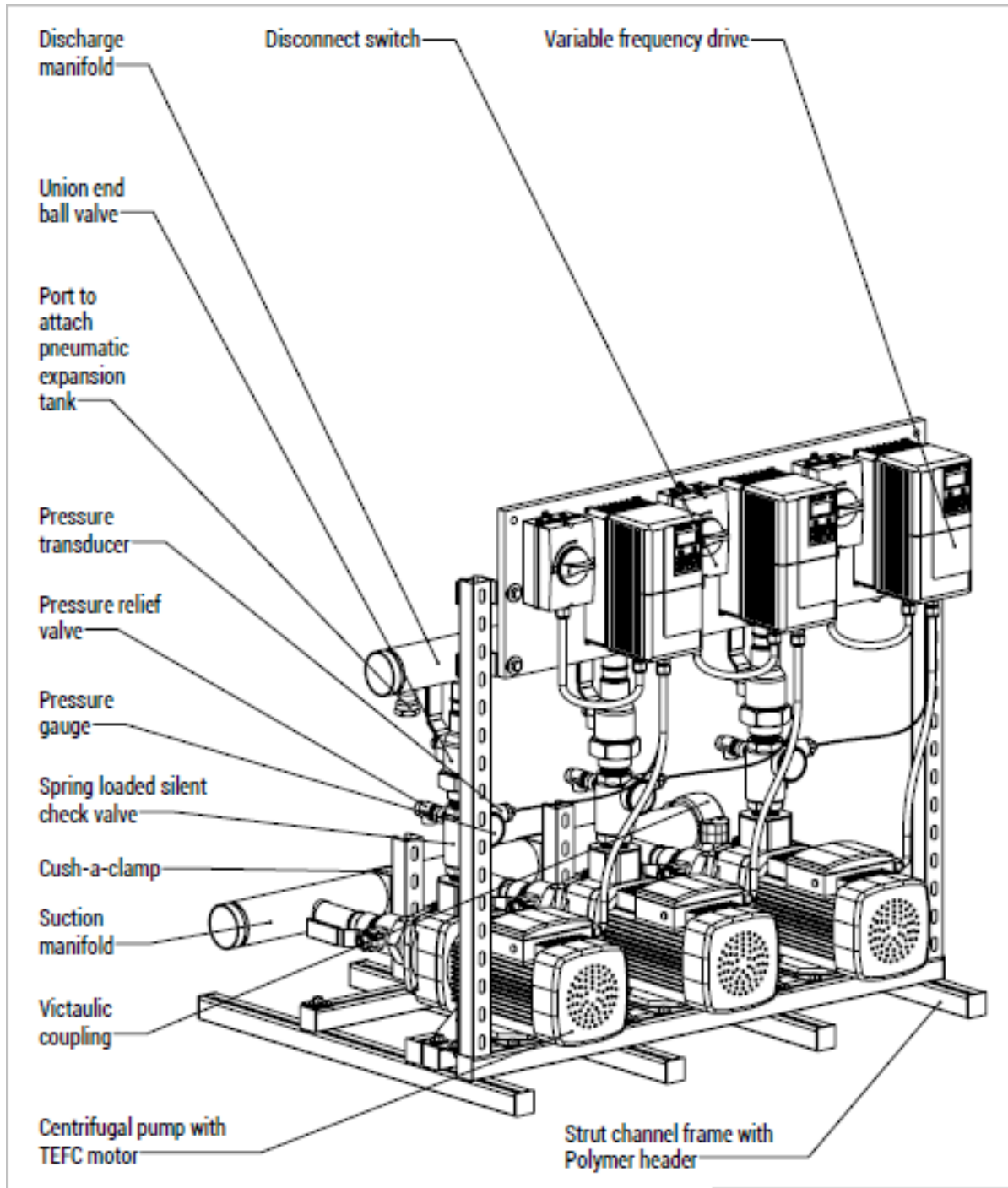

<p>PROPRIETARY AND CONFIDENTIAL THE INFORMATION CONTAINED IN THIS DRAWING IS THE SOLE PROPERTY OF TOWLE WHITNEY LLC. ANY REPRODUCTION IN PART OR AS A WHOLE WITHOUT THE WRITTEN PERMISSION OF TOWLE WHITNEY LLC IS PROHIBITED.</p>		<p>DIMENSIONS ARE SUBJECT TO CHANGE DO NOT USE FOR CONSTRUCTION UNLESS OTHERWISE SPECIFIED DIMENSIONS ARE IN INCHES</p>		<p>TOWLE WHITNEY LLC</p>	
		<p>DO NOT SCALE DRAWING</p>		<p>Triplex Variable Speed Booster System</p>	
		<p>DATE 10/12/22</p>	<p>DATE 10/12/22</p>	<p>DRWG. NO. 2022-10-12-A</p>	
		<p>SCALE: 1/2" = 1'-0"</p>		<p>WEIGHT: _____</p>	
				<p>SHEET 1 OF 1</p>	

SYSTEM DIMENSIONS

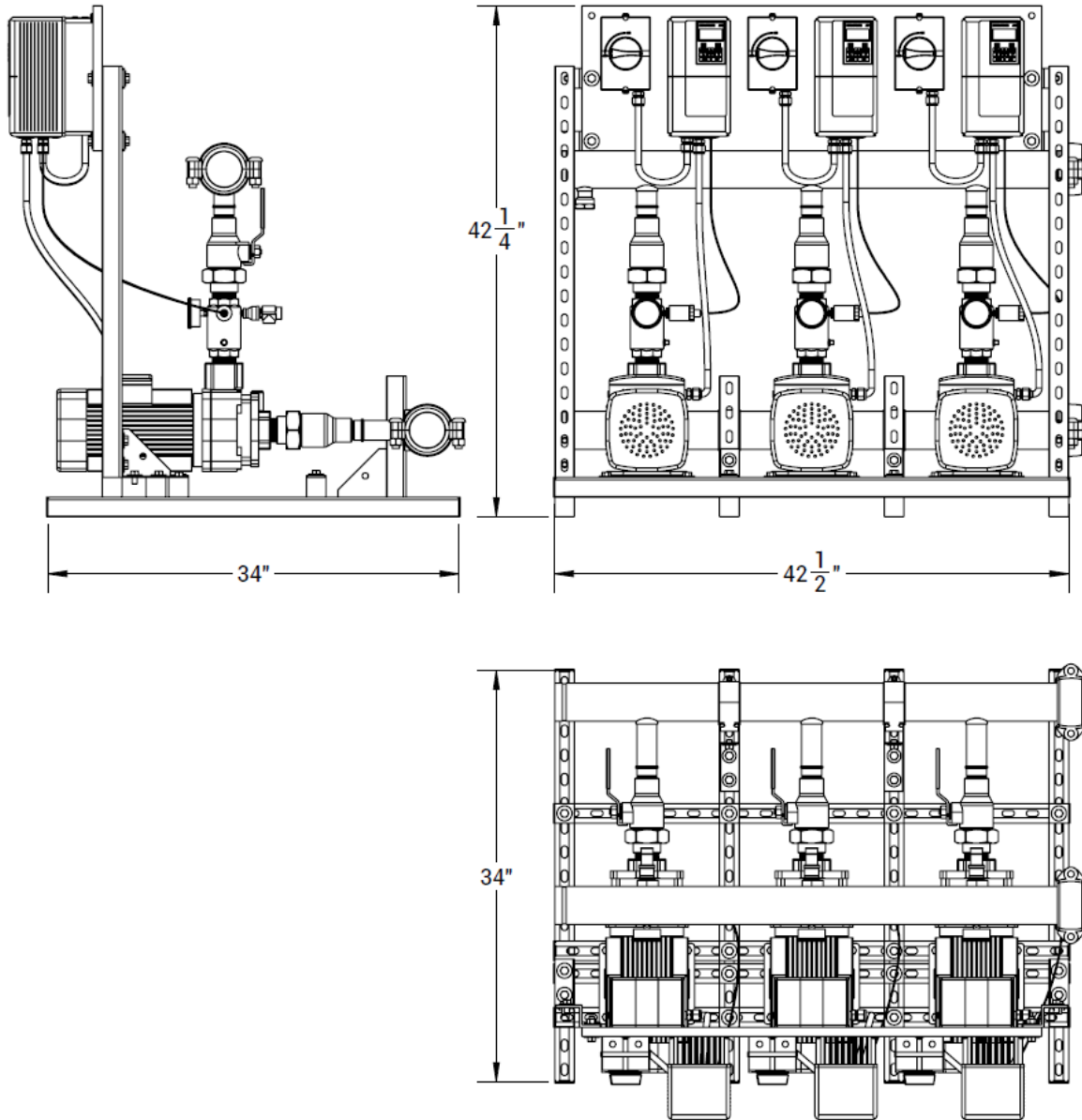

PROPRIETARY AND CONFIDENTIAL
THE INFORMATION CONTAINED IN THIS DRAWING IS THE SOLE PROPERTY OF TOWLE WHITNEY LLC. ANY REPRODUCTION IN PART OR AS A WHOLE WITHOUT THE WRITTEN PERMISSION OF TOWLE WHITNEY LLC IS PROHIBITED.

DIMENSIONS ARE SUBJECT TO CHANGE
DO NOT USE FOR CONSTRUCTION
UNLESS OTHERWISE SPECIFIED
DIMENSIONS ARE IN INCHES

DO NOT SCALE DRAWING

	NAME	DATE
DRAWN:	VID	10/12/22
CHECKED:	DW	10/12/22
COMMENTS:		

TOWLE WHITNEY LLC

Triplex Variable Speed Booster System

SIZE: **A** DWG. NO. **2022-10-12-B**

SCALE: 1:24 WEIGHT:

SHEET 1 OF 1

REV.

Assembled Units:

- All “wetted surfaces” shall be lead free (<.25% Pb) in conformance with the 1/4/14 federal law
- Shall include a separate and independent variable frequency drive (VFD) for each pump with a pressure transducer, pressure gauge, and relief valve. Piping and frame shall not interfere with access to the controls
- Each pump shall include isolation valves on both the suction and discharge piping
- Each pump shall have a separate and independent disconnect box
- Shall be mounted on a frame for ease of transport and installation.

Variable frequency drive:

- Will ALTERNATE the lead pump every 24 hours (field adjustable) of run time. The lag pump shall be in standby
- Shall have hands-off automatic (HOA) capability
- Rated to operate using specified power requirement. The drive efficiency shall be 98% or better
- Have UL approval with all factory installed options and preset values and/or last saved data values will remain available to the operator after power outage
- Shall have at least NEMA 1 rated conduit enclosure
- The program will protect the pumps against damaging hydraulic conditions such as:
 - Motor overload, Pump overflow surges, Loss of prime due to incoming water supply interruption, Hunting
 - Protection from overload through frequency/current optimization
 - Protection from hydraulic damage by restricting the pumps to operate beyond their published end of curve
- Shall have the ability to automatically restart after an over-current, over-voltage, under-voltage or loss of input signal
- Shall have an operator control panel [keypad] for customization of parameters
- Shall include a feature to upload/download parameters into an external device to be used with another drive or the same drive
- Shall have a removable non-volatile memory device
- Shall be capable of accepting individual analog inputs from transducer. All transducer inputs must be wired to the variable frequency drive for continuous scan and comparison function
- Ladder logic program shall utilize a proportional - integral - derivative control function
- Shall display the following values:
 - Pump running/standby, Pump speed in Hz, User adjustable parameters such as PID set points, Motor frequency, Motor current, Threshold set points for PID error, Min operating frequency, Troubleshooting and diagnostics of faults

Transducer:

- The transducer shall be rated for required system pressure and shall be 4-20 mA analog
- Separate transducers shall be supplied for each variable frequency drive to ensure redundancy

Centrifugal pump:

- Shall have a cast iron casing with bronze fitted impellers.
- Shall have a 316 stainless steel shaft sleeve. Mechanical seal shall be rated to withstand pressure of up to 142 PSI
- Motor shall be to totally enclosed fan cooled (TEFC). and manufactured in compliance with CE, RoHS and CSA

Pneumatic expansion tank:

- Pneumatic expansion tank shall be rated for use with potable water with an operating pressure of a maximum 125 PSI
- Pre-charged to a pressure of 10 PSI below system operating pressure for system to run properly

Manifolds, valves and fittings:



- Manifolds are designed for either right or left access
- Shall be sized appropriately to allow water velocity not exceeding 10 ft/sec, to minimize cavitation and turbulence
- Check valves shall be silent and spring-loaded

Installation:



- Equipment shall be installed in accordance with applicable local building, electrical and plumbing codes
- Shall be installed indoors (unless otherwise specified) and protected from water spray

COMPONENT COMPLIANCE

Electrical

Yaskawa VFD	UL 508C Power Conversion CSA 22.2 Industrial Controls		CE	RoHS
Lovato Shut-off	NEMA4		CE	RoHS

Pumps

Grundfos CM(I) SS Series	NSF 61		CE	
Grundfos CR(I) SS Series	NSF 61		CE	
Goulds 125MS Series	NSF 61		CE	
Goulds BF Series	NSF 61		CE	
Walrus TPH Series	NSF 372		CE	RoHS

Plumbing

Bluefin BVT200 Ball Valves	NSF 61			
Webstone BVT200 Ball Valves	NSF 61			
Bonomi Check 1000012	NSF 61		CE	
Flomatic VFD Check	NSF 61			
Victaulic 607 "E" Coupling	NSF 61			
Victaulic 660 Cap	NSF 61			
Amtrol PL Tank	NSF 61			
Watts PLT Tank	NSF 61			
Manifolds / piping	Type L Copper			
Fittings	Copper			
Discharge Riser	Copper		CE	
- Pressure Relief valve:				
- SS 4-20mA Transducer:				
- Pressure Gauges:	CA AB1953			

Sealants

Rectorseal Nokorode Flux	NSF 61
Worthington SILVER Solder	NSF 61
LocTite 567 Thread Sealant	NSF 61
Gasola Thread Sealant	NSF 61



Warranty: Provide VFD warranty, for one year from startup, not to exceed 18 months from the date of shipment. Warranty shall include parts, and labor allowance for repair hours.



Performance Features (Drive)

- Ratings:
1 to 5 HP at 200-240 VAC 1-Ph.
1 to 25 HP (ND) at 200-240 VAC 3-Ph.
1 to 25 HP (ND) at 380-480 VAC 3-Ph.
- Overload Capacity:
120% for 60 sec. (Normal Duty)
- Control Methods: V/f Control,
Open Loop Current Vector Control
- DC injection braking, ramp to stop
- Electronic reversing
- Adjustable accel/decel: 0.01 to 6000 seconds
- Controlled speed range:
40:1⁽¹⁾ 100:1⁽²⁾
- Speed Regulation:
± 0.5 to 1% with slip compensation⁽¹⁾
± 0.2%⁽²⁾
- Displacement power factor: 0.98
- Output frequency: 0 to 400 Hz
- Frequency resolution:
0.01 Hz with digital reference
0.06 / 60 Hz with analog reference
- Frequency accuracy:
0.01% with digital command
0.5% with analog command
- Volts / hertz ratio: infinitely adjustable pattern
- DC Injection braking: adjustable amplitude, duration, current limited
- Torque boost: full range, auto
- Power loss ride-thru: 0.5 sec.
- Speed search
- Auto restart
- 3 Critical frequency rejection settings
- Slip Compensation
- Energy Savings Function
- Enhanced PID with loss of feedback function

⁽¹⁾ V/f Mode

⁽²⁾ Open Loop Current Vector Mode

Design Features (Drive)

- Dual microprocessor logic
- Digital keypad operator, 5 digits
- LED status display
- Remote Mount Keypad Capability
- RJ-45 Style Digital Operator Connector
- 7 multifunction digital inputs
- 3 multifunction digital outputs
- Hardwire baseblock (EN954-1 Cat. 3)
- Programmable form C output contact for customer use: 1A at 250 VAC or 30 VDC
- 24 VDC control logic compatible with sourcing or sinking outputs (PNP or NPN)
- Carrier frequency: 15 kHz max; swing PWM
- 2 Remote speed references:
0-10 VDC (20 kohms) or isolated 4-20 mA (250 ohms)
- Signal follower: bias and gain
- 2 programmable open collector outputs
- Analog monitor output:
0-10 VDC proportional to output frequency or output current
- Approx. 400 parameters and monitors
- Digital pulse train input (33 kHz max.)
- Cooling fan controlled by drive run/stop
- RS-422/485 Modbus 115 kbps
- UL recognized electronic overload
- MTBF: 28 years
- NEMA 1 enclosure
- Side-by-Side mounting
- Maintenance monitors

Protective Features (Drive)

- Current limit, stall prevention during accel, decel, and run
- Motor and drive overload
- Over voltage prevention function
- Instantaneous over current
- Short circuit
- Under voltage
- Heatsink overheat
- Ground fault protection
- Over/under torque
- Short circuit current rating: 30kA rms sym.

Pump Control Features

- Operator keypad with intuitive pump language
- Hand-Off-Auto
- Programmable pump process set point
- Pump start level and start time
- Sleep protection
- Simplex, duplex and triplex control
- Automatic system restart
- No flow detection
- Low and high feedback set points
- Pre-charge low level control
- Thrust bearing control
- Automatic system stabilization
- Motor condensation pre-heat function

Pump Protective Features

- Dry well
- Air in system
- Blocked impeller
- Pump over cycling
- No flow protection
- Loss of prime
- Transducer loss
- Over torque

Pump Alarms and Messages

- Low feedback
- High feedback
- Low level
- Low water
- Pump over cycling
- No flow detection
- Loss of prime
- Pump fault
- Motor thermostat
- Pre-charge mode
- Thrust bearing active
- Start mode active
- Sleep mode active

3656 S-GROUP DIMENSIONS AND WEIGHTS
GRUPO S, MODELO 3656 - PESO Y DIMENSIONES

MECHANICAL SEAL
SELLO MECÁNICO

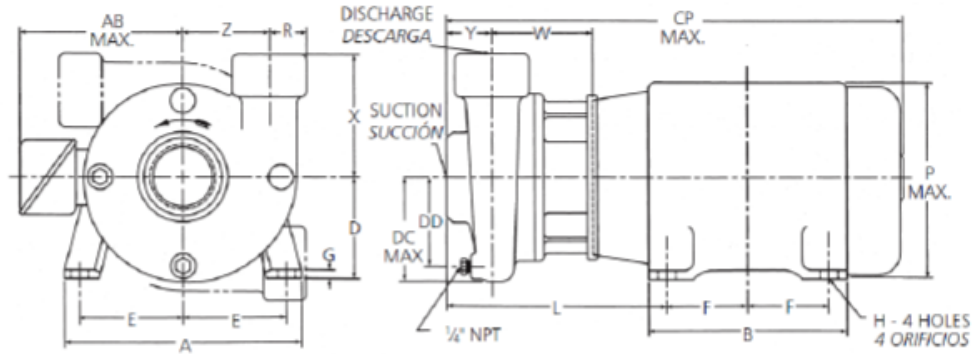

Pump Dimensions and Weights (Dimension "L" determined by Pump and Motor)
Peso y dimensiones de la bomba (la dimensión "L" está determinada por la bomba y el motor)

Pump Bomba	Suction Succión	Discharge Descarga	CP Max.	DC Max.	DD	R	W	X	Y	Z	Wt. (lbs.) Pesos (libras)	Motor Frame Size, Bastidor			
												140	180	210	250
1 x 2 - 7	2	1	27	4 1/4	3 1/2	1 1/8	4 1/2	5 1/2	3	4	52	10	10 1/4	—	—
1 x 2 - 8					4	3 1/8	5 1/4	3 1/8	4 1/4	52	—			—	
1 1/2 x 2 - 6		1 1/2	23 3/4	3 1/2	1 1/4	4 1/2	4 1/2	2 1/2	3 1/2	34	9 1/4	10 1/2	—	—	
1 1/2 x 2 - 8	3	2 1/2	25 1/2	5 1/8	4 1/2	1 1/8	4 1/2	5	3	4	49	10 1/2	10 1/4	11 1/2	11 1/2
2 1/2 x 3 - 7														4	25 1/2
3 x 4 - 7	4"	3"	25 1/4	5 1/4	5 1/8	3 1/4	4 1/8	—	—	—	—	—	—	—	—

*For use with ANSI class 150 mating flange. All others are NPT connections.
* Para uso con brida de contacto ANSI clase 150. Todas las demás son conexiones NPT.

Motor Dimensions and Weights (may vary with manufacturer)*
Peso y dimensiones del motor (pueden variar de acuerdo al fabricante) *

Frame Size JM Tamaño del bastidor JM	A	AB (Max.)	B	D	E	F	G	H	P (Max.)	Weight (lbs.) Pesos (libras)
143	6 1/2	5 1/4	6	3 1/2	2 3/4	2	1/8	1 1/2	6 1/2	41
145						2 1/2				57
182	8 1/2	5 3/8	6 1/2	4 1/2	3 3/4	2 1/4	3/16	1 3/2	7 1/4	77
184						2 3/4				97
213	9 1/2	7 3/4	8	5 1/4	4 1/4	2 3/4	7/32	1 3/2	9 1/2	122
215						3 1/2				155
254 TCZ	11 1/4	9	9 1/2	6 1/4	5	4 1/8	1/4	1 3/2	11 1/2	265
256 TCZ			11 1/4			5				320

NOTE:
All pumps shipped in vertical discharge position. May be rotated in 90° increments. Tighten casing bolts to 25 ft./lbs. torque.

NOTA:
Todas las bombas se embarcan con la descarga en posición vertical. Esta posición puede rotarse en incrementos de 90°. Ajustar los pernos de la carcasa a una torsión de 25 pies/libras.

Motor Frames and Horsepower
Bastidores del motor y potencia en HP

Motor Frame Bastidor del motor	3500 RPM				1750 RPM			
	1 Phase		3 Phase		1 Phase		3 Phase	
	ODP	TEFC	ODP	TEFC	ODP	TEFC	ODP	TEFC
143	—	3/4, 1, 1 1/2	3/4, 1, 1 1/2	3/4, 1, 1 1/2	—	1/2, 3/4	1/2, 3/4, 1	1/2, 3/4, 1
145	—	2	2, 3	2, 3	—	1, 1 1/2	1 1/2, 2	1 1/2, 2
182	3	3	5	3	3	2, 3	3	3
184	5	3, 5	7 1/2	5	—	—	5	5
213	7 1/2	—	10	7 1/2	5	—	7 1/2	7 1/2
215	10	—	15	10, 15	—	—	—	—
254TCZ	—	—	20	—	—	—	—	—
256TCZ	—	—	25	20, 25	—	—	—	—

All dimensions in inches and weights in lbs. Do not use for construction purposes.
Todas las dimensiones están en pulgadas, el peso en libras. No utilizar para fines de construcción.

3656 S-GROUP MATERIALS OF CONSTRUCTION
MATERIALES DE CONSTRUCCIÓN - GRUPO S, MODELO 3756

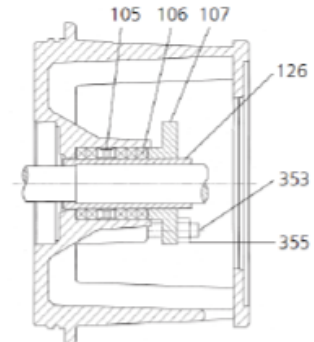
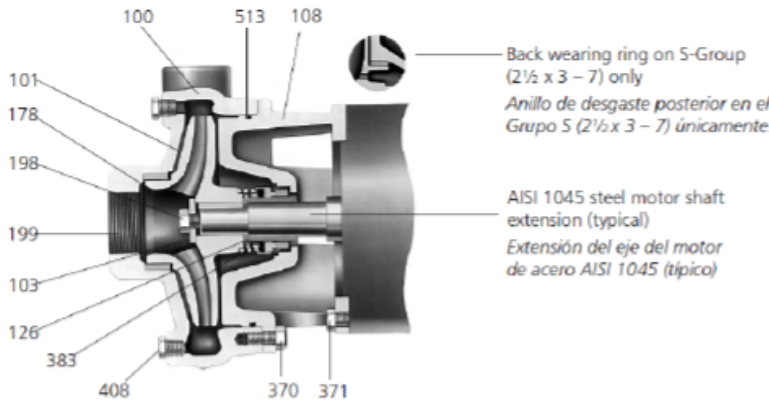

Packed Box Arrangement
Caja prensaestopas

Item No. No. ítem	Description Descripción	Materials, Materiales		
		All Iron Todo hierro	Bronze Fitted Accesorios de bronce	All Bronze Todo bronce
100	Casing, Carcasa	1001	1001	1101
101	Impeller, Impulsor		1101	
103	Casing wear ring, Anillo de desgaste de la carcasa		1618	1618
108	Adapter, Adaptador		1001	1001
184	Seal housing, Cubierta del sello ①	One piece with adapter, Una pieza con adaptador		1101
126	Shaft sleeve, Camisa del eje	AISI Type 300 series stainless steel Acero inoxidable serie AISI tipo 300		
198	Impeller bolt, Perno del impulsor			
199	Impeller washer, Arandela del impulsor			
178	Impeller key, Chaveta del impulsor	Carbon Steel, Acero al carbono		
370	Hex head cap screw (adapter to case), Tornillo de cabeza hexagonal (del adaptador a la cubierta)	Steel SAE 1200 Grade 5 Acero SAE 1200 grado 5		
371	Hex head cap screw (adapter to motor), Tornillo de cabeza hexagonal (del adaptador al motor)			
383	Mechanical seal, Sello mecánico	See seal chart, Ver tabla del sello		
408	Pipe plug ¼" or ⅜", Tapón de tubos de ¼ de pulgada ó ⅜ de pulgada	Steel, Acero		Bronze, Bronce
513	O-ring, Anillo en O	BUNA-N, BUNA-N		

Material Code, Código de material	Engineering Standard, Norma de ingeniería
1101	Cast iron ASTM A48 CL20, Hierro fundido ASTM A48 CL20
1101	Silicon bronze ASTM B584, C87500, Siliuro de bronce ASTM B584, C87500
1618	Bismuth brass, Latón al bismuto

Packed Box Arrangement, Caja prensaestopas			
Item No., No. ítem	Description, Descripción	Materials, Materiales	
105	Lantern ring, Aro de linterna	Teflon™	
106	Packing, 5 rings; Empaquetadura, 5 aros	Teflon Impregnated, Impregnado de Teflon	
107	Gland, Casquillo	AISI 316SS	
126	Shaft sleeve, Camisa del eje	AISI Type 300 Series Stainless Steel Acero inoxidable serie AISI tipo 300	
353	Gland stud, Perno del casquillo		
355	Gland nut, Tuerca del casquillo		

Type 21 Mechanical Seal, Tipo 21 sello mecánico					
Seal Code, Código del Sello	Rotary, Rotativo	Stationary, Estacionario	Elastomers, Elastómeros	Metal Parts, Partes Metálicas	Part No., Pieza Número
0	Carbon, Carbón	Ceramic, Cerámica	BUNA-N	316 SS, 316 Acero inoxidable	10K13
1					EPR
3	Sil-Carbide, Carburo de sílice	Viton	10K27		
5			10K64		
9	Packed Box Design with BUNA O-Ring, Diseño de prensaestopas empacado con anillo en O de BUNA				15K16

① For separate seal housing and adapter construction, all bronze material only, see repair parts page.
Para la construcción separada del compartimiento del sello y el adaptador, materiales de bronce únicamente, consulte la página de piezas de repuesto.

NOTE:
Pumps will be shipped with top-vertical discharge position as standard. For other orientations, remove casing bolts – rotate discharge to desired position – replace and tighten bolts to 25 ft./lbs. Note that discharge may extend below motor mounting surface in bottom-horizontal position; adequate clearance must be provided.

NOTA:
Las bombas salen de la fábrica con la descarga orientada en posición vertical superior de manera estándar. Para modificar la orientación, retirar los pernos de la carcasa, hacer girar la descarga hasta la posición deseada y volver a colocar los pernos, ajustándolos a una torsión de 25 pies/libras. Se ha de notar que la descarga se puede extender por debajo de la superficie de montaje del motor en la posición horizontal inferior; por lo tanto, debe proveerse suficiente espacio.

PNEUMATIC EXPANSION TANK SPECIFICATIONS



PRO-LINE®
Diaphragm Well Tanks: PL Series

125 PSIG Working Pressure

Construction

Shell	Deep Drawn Steel
Diaphragm	Butyl
Liner	Polypropylene
System Connection	304L Stainless Steel
Finish	Tan
Water Circulator	Turbulator™
Air Valve	Projection Welded
Factory Precharge	38 PSIG (2.6 bar)

Application

• Controls pump cycling in residential well water systems.

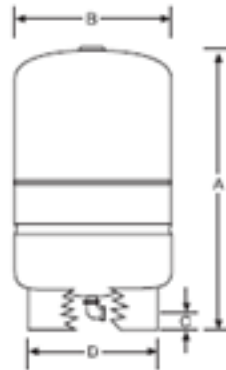

Performance

Maximum Operating Temperature	200°F (93°C)
Maximum Working Pressure	125 PSIG (8.6 bar)
Maximum Relief Valve Setting	100 PSIG (6.9 bar)
Warranty	5 Year

Stand Models

Model	Tank Volume		Max. Accept. Factor	A Tank Height		B Tank Diameter		C Sys. Conn. Centerline		D Stand Diameter		System Conn. (NPTF)	Shipping Weight	
	Gal	Lit		in	mm	in	mm	in	mm	in	mm		Lbs	Kg
PL-14	14.0	53	0.81	25	635	15	381	1 1/4	40	12	304	1	22	10
PL-20	20.0	76	0.57	32	813	15	381	1 1/4	40	12	304	1	28	13
PL-26	26.0	98	0.44	39	991	15	381	1 1/4	40	12	304	1	34	15
PL-32	32.0	121	0.35	47	1194	15	381	1 1/4	40	12	304	1	40	18
PL-34	34.0	129	1.00	30	762	22	559	1 1/4	49	20 1/2	521	1 1/4	50	23
PL-44	44.0	167	0.77	38	914	22	559	1 1/4	49	20 1/2	521	1 1/4	57	26
PL-62	62.0	235	0.55	47	1194	22	559	1 1/4	49	20 1/2	521	1 1/4	75	34
PL-81	81.0	301	0.41	57	1448	22	559	1 1/4	49	20 1/2	521	1 1/4	92	42
PL-86	86.0	326	0.54	47	1194	26	660	2 1/4	52	20 1/2	521	1 1/4	99	45
PL-119	119.0	450	0.39	62	1575	26	660	2 1/4	52	20 1/2	521	1 1/4	133	60

All dimensions and weights are approximate.



Booster Pump Systems

Three Year Limited Warranty

This warranty applies to booster pump systems built by Towle Whitney LLC, and shall:

- Exist 36 months from the date of shipment.
- Be in effect only after installation photographs are received by Towle Whitney LLC.

Towle Whitney LLC liability under this warranty shall be limited to the repair or replacement of any part or parts found to be defective (material or workmanship) within the warranty period. Towle Whitney LLC shall determine whether the part needs to be returned, or field scrapped. The warranty excludes:

- Any water damage or consequential damage.
- Transducers & Pump Seals.
- Debris in water causing damage to pump internal parts.
- Systems not installed in accordance with Installation and Maintenance Instructions.
- Labor, transportation, and related costs incurred by the customer.
- Misuse, negligence, inappropriate chemicals or additives in water.
- Inadequate protection from freezing.
- Lightning, high voltage spikes, accidents, floods, or acts of God.
- Re-Installation costs of repaired or replacement equipment.
- Re-Imbursement for the loss caused by interruption of service.
- Adjusting drive parameters without consulting Towle Whitney.

This warranty applies to all states and territories of the United States and Canada only. There are no express or implied warranties, including merchantability or fitness for a particular purpose, which extend beyond those warranties described or referred to above.

Some jurisdictions do not allow the exclusion or limitation of incidental or consequential damages and some jurisdictions do not allow limit actions on how long implied warranties may last. Therefore, the above limitations or exclusions may not apply. This warranty gives you specific legal rights and you may also have other rights which vary from jurisdiction to jurisdiction.