



**TW3018V-360R-100
TRIPLEX
VARIABLE SPEED BOOSTER SYSTEM**

The **TW3018V-360R-100 Triplex Vertical Booster System** is equipped with centrifugal pumps regulated by a variable frequency drive that controls the pump operation to maintain constant pressure regardless of varying demand and fluctuation in incoming pressure.

System is built on a MODULAR frame for ease of transport and installation.

VFD drives will ALTERNATE lead pump every 24 hours of run time. 2nd pump will remain in standby.



*All parts shown included
Actual system components may vary
Some assembly required*

Lead-Free (Wetted) components:

- Pumps: SS and Cast Iron
- Relief valves: Lead Free Brass
- Pressure Gauges: Stainless Steel
- Transducer: Stainless Steel
- Check valves: Lead Free Brass
- Ball Valves: Lead Free Brass
- Manifolds: Lead Free Type L Copper
- Fittings: Lead Free Copper
- Flanges: Stainless Steel
- Thermal Valves: Stainless Steel

* All lead free brass shall contain < .25% Pb

Technical Specifications:

- Pump:** Grundfos CR32-3
- Horse Power:** 15 HP
- Controller:** Yaskawa
- Flow Rate:** 360 GPM (120 GPM / Pump)
- Boost:** 100 PSI Boost (230' tdh)
- Manifolds:** 4 inch
- Tank:** 32 Gallon non-ASME
- Frame Size:** 48" W x 54" H x 34" D
- Power options:** Three Independent circuits recommended
200-240V/1 Phase
200-240V/3 Phase
360-480V/3 Phase

Specify when ordering

SYSTEM CONFIGURATION

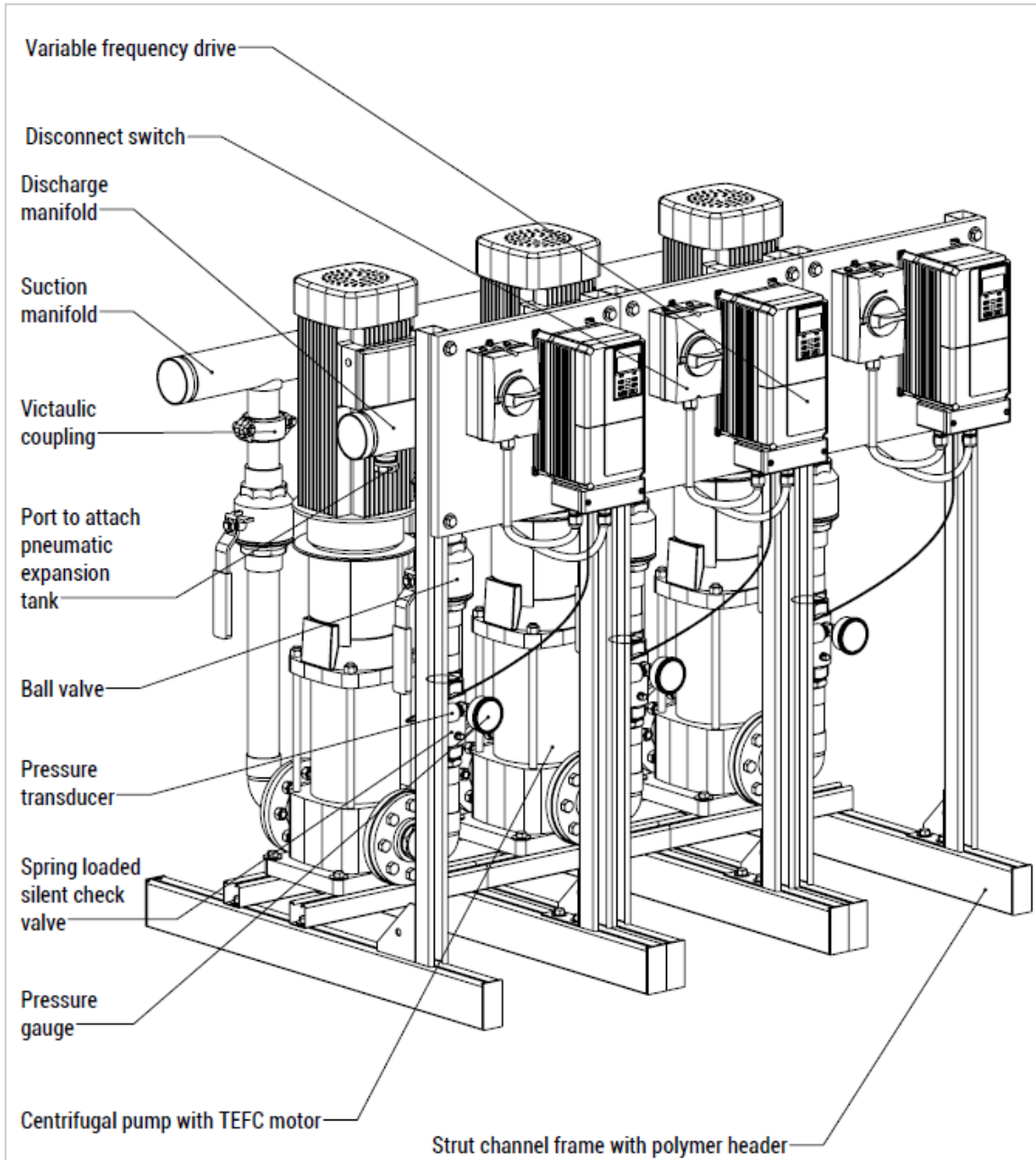

<p>PROPRIETARY AND CONFIDENTIAL THE INFORMATION CONTAINED IN THIS DRAWING IS THE SOLE PROPERTY OF TOWLE WHITNEY LLC. ANY REPRODUCTION IN PART OR AS A WHOLE WITHOUT THE WRITTEN PERMISSION OF TOWLE WHITNEY LLC IS PROHIBITED.</p>		<p>DIMENSIONS ARE SUBJECT TO CHANGE DO NOT USE FOR CONSTRUCTION UNLESS OTHERWISE SPECIFIED DIMENSIONS ARE IN INCHES</p>		<p>NAME DATE DRAWN VID 3/29/22 CHECKED DW 3/29/22 COMMENTS:</p>		<p>TOWLE WHITNEY LLC</p>	
		<p>DO NOT SCALE DRAWING</p>		<p>Vertical Triplex Variable Speed Booster System</p>		<p>SIZE DWG. NO. 2022-03-29-C REV. A</p>	
				<p>SCALE: 1:24 WEIGHT:</p>		<p>SHEET 1 OF 1</p>	

SYSTEM DIMENSIONS

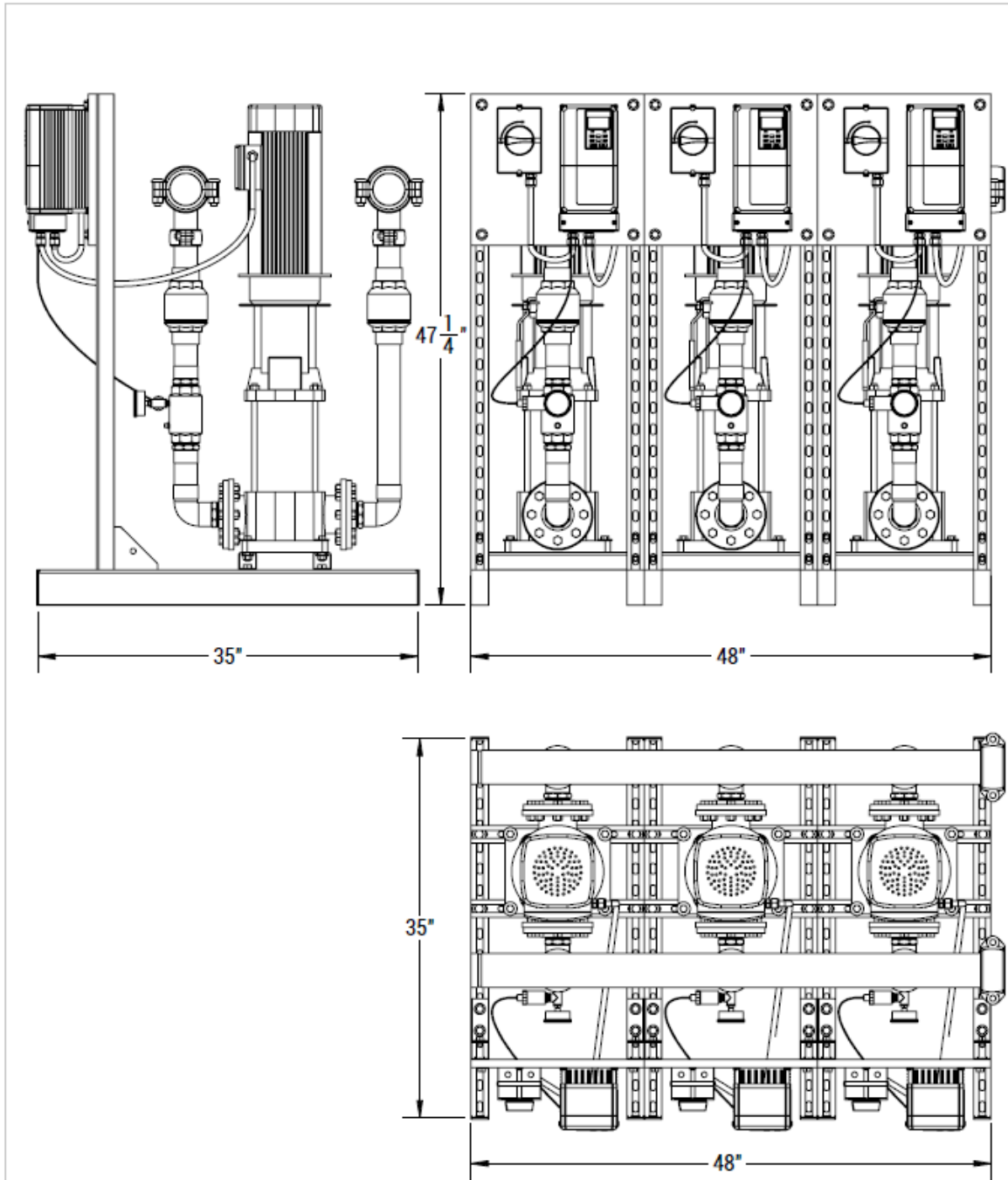

PROPRIETARY AND CONFIDENTIAL
THE INFORMATION CONTAINED IN THIS
DRAWING IS THE SOLE PROPERTY OF
TOWLE WHITNEY LLC. ANY
REPRODUCTION IN PART OR AS A WHOLE
WITHOUT THE WRITTEN PERMISSION OF
TOWLE WHITNEY LLC IS PROHIBITED.

DIMENSIONS ARE SUBJECT TO
CHANGE
DO NOT USE FOR
CONSTRUCTION
UNLESS OTHERWISE SPECIFIED
DIMENSIONS ARE IN INCHES

DO NOT SCALE DRAWING

	NAME	DATE
DRAWN	VID	3/29/22
CHECKED	DW	3/29/22
COMMENTS:		

TOWLE WHITNEY LLC

**Vertical Triplex Variable Speed
Booster System**

SIZE	DWG. NO.	REV.
A	2022-03-29-D	
SCALE: 1:24	WEIGHT:	SHEET 1 OF 1

CR, CRN 32

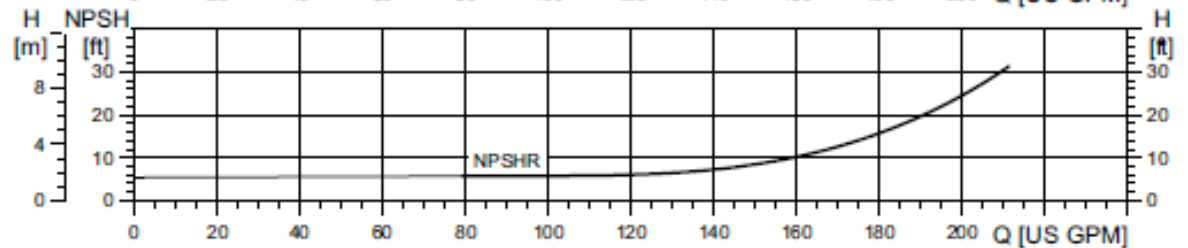
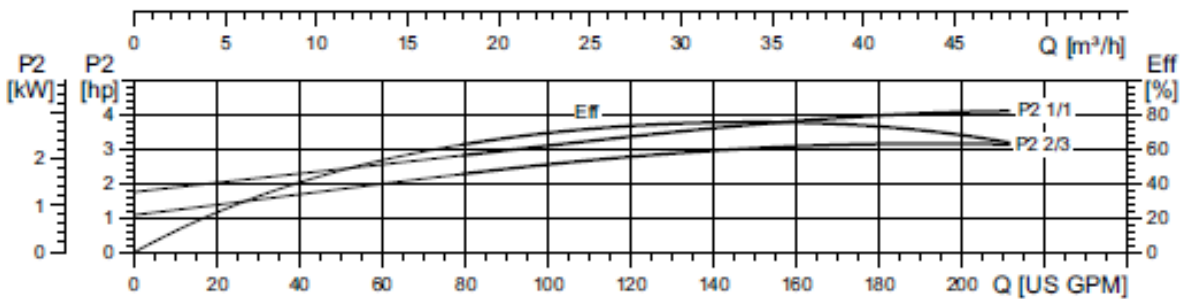
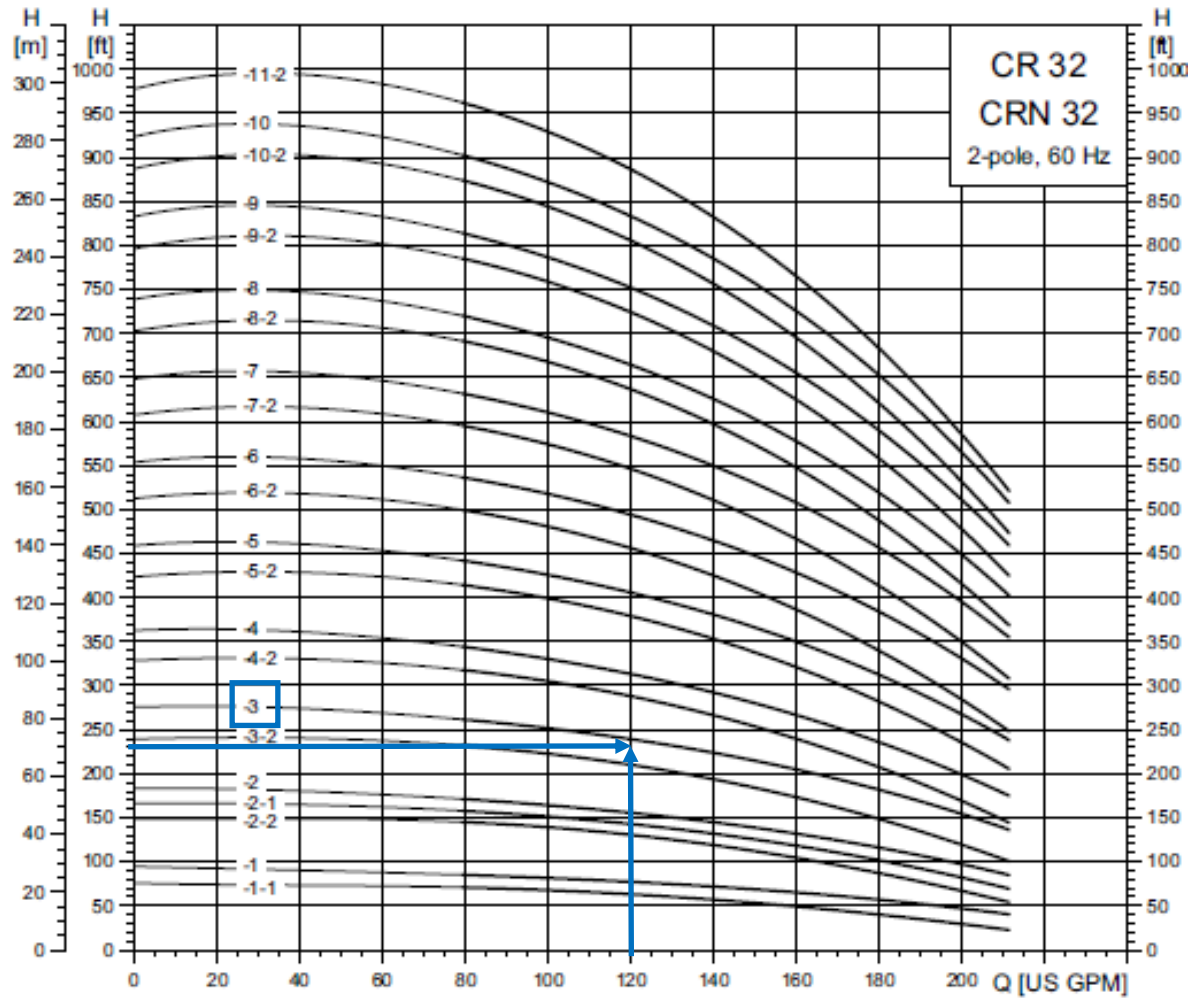

CR 32

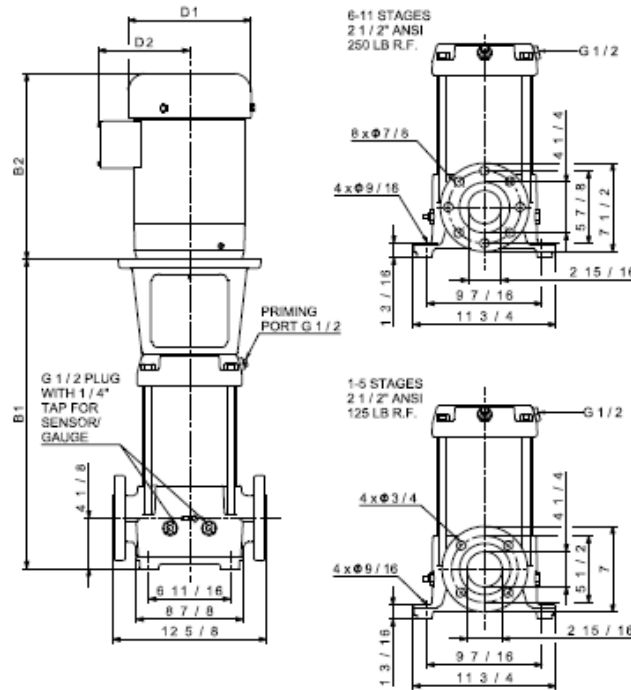

TMO2 7699 1009

Pump-type	P2 [Hp]	Ph.	ANSI dimensions [inch (mm)]								
			B1	TEFC			ODP			Ship. wt. ¹⁾ [lbs (kg)]	
				D1	D2	B1+B2	D1	D2	B1+B2		
CR 32-1-1	5	1	20.08 (511)	10.62 (270)	7.46 (190)	35.60 (905)	-	-	-	240 (109)	
			19.88 (505)	8.66 (220)	5.28 (135)	35.39 (899)	-	-	-	218 (99)	
CR 32-1	5	1	20.08 (511)	10.62 (270)	7.46 (190)	35.60 (905)	-	-	-	228 (104)	
			19.88 (505)	8.66 (220)	5.28 (135)	35.39 (899)	-	-	-	218 (99)	
CR 32-2-2	7 1/2	1	22.83 (580)	10.22 (260)	7.62 (194)	38.36 (975)	-	-	-	245 (112)	
			22.64 (576)	8.66 (220)	5.28 (135)	38.15 (970)	-	-	-	229 (104)	
CR 32-2-1	7 1/2	1	22.83 (580)	10.22 (260)	7.62 (194)	38.36 (975)	-	-	-	245 (112)	
			22.64 (576)	8.66 (220)	5.28 (135)	38.15 (970)	-	-	-	229 (104)	
CR 32-2	10	1	22.83 (580)	10.23 (260)	10.30 (262)	38.90 (989)	-	-	-	300 (137)	
			22.64 (576)	10.24 (261)	6.26 (160)	37.87 (962)	-	-	-	229 (104)	
CR 32-3-2	10	1	25.59 (650)	10.23 (260)	10.30 (262)	41.66 (1059)	-	-	-	295 (134)	
			25.39 (645)	10.24 (261)	6.26 (160)	40.12 (1020)	-	-	-	236 (108)	
CR 32-3	15	3	29.72 (755)	12.36 (314)	8.00 (204)	48.28 (1228)	10.62 (270)	7.33 (187)	46.03 (1170)	332 (151)	
CR 32-4-2	15	3	32.48 (825)	12.36 (314)	8.00 (204)	51.02 (1296)	10.62 (270)	7.33 (187)	48.79 (1240)	339 (154)	
CR 32-4	20	3	32.48 (825)	12.36 (314)	8.00 (204)	51.02 (1296)	11.50 (293)	8.92 (227)	52.17 (1326)	344 (157)	
CR 32-5-2	20	3	35.24 (896)	12.36 (314)	8.00 (204)	53.78 (1367)	11.50 (293)	8.92 (227)	54.93 (1396)	351 (160)	
CR 32-5	20	3	35.24 (896)	12.36 (314)	8.00 (204)	53.78 (1367)	11.50 (293)	8.92 (227)	54.93 (1396)	351 (160)	
CR 32-6-2	25	3	37.99 (965)	12.36 (314)	8.00 (204)	60.38 (1534)	11.50 (293)	8.94 (228)	58.80 (1494)	351 (160)	
CR 32-6	25	3	37.99 (965)	12.36 (314)	8.00 (204)	60.38 (1534)	11.50 (293)	8.94 (228)	58.80 (1494)	351 (160)	
CR 32-7-2	30	3	40.75 (1036)	12.36 (314)	8.00 (204)	63.14 (1604)	11.50 (293)	8.94 (228)	62.56 (1590)	444 (202)	
CR 32-7	30	3	40.75 (1036)	12.36 (314)	8.00 (204)	63.14 (1604)	11.50 (293)	8.94 (228)	62.56 (1590)	423 (192)	
CR 32-8-2	30	3	43.50 (1105)	15.32 (390)	8.00 (204)	65.89 (1674)	11.50 (293)	8.94 (228)	65.31 (1659)	436 (198)	
CR 32-8	40	3	43.50 (1105)	15.32 (390)	13.11 (333)	66.69 (1694)	13.25 (337)	12.21 (311)	66.75 (1696)	631 (287)	
CR 32-9-2	40	3	46.26 (1176)	15.32 (390)	13.11 (333)	69.45 (1765)	13.25 (337)	12.21 (311)	69.51 (1766)	637 (289)	
CR 32-9	40	3	46.26 (1176)	15.32 (390)	13.11 (333)	69.45 (1765)	13.25 (337)	12.21 (311)	69.51 (1766)	637 (289)	
CR 32-10-2	40	3	49.02 (1246)	15.32 (390)	13.11 (333)	72.21 (1835)	13.25 (337)	12.21 (311)	72.27 (1836)	645 (293)	
CR 32-10	40	3	49.02 (1246)	15.32 (390)	13.11 (333)	72.21 (1835)	13.25 (337)	12.21 (311)	72.27 (1836)	645 (293)	
CR 32-11-2	50	3	51.77 (1315)	16.88 (429)	14.12 (359)	79.58 (2022)	13.25 (337)	12.21 (311)	74.52 (1893)	671 (305)	

..

Assembled Units:

- All “wetted surfaces” shall be lead free (<.25% Pb) in conformance with the 1/4/14 federal law
- Shall include a separate and independent variable frequency drive (VFD) for each pump with a pressure transducer, pressure gauge, and relief valve. Piping and frame shall not interfere with access to the controls
- Each pump shall include isolation valves on both the suction and discharge piping
- Each pump shall have a separate and independent disconnect box
- Shall be mounted on a frame for ease of transport and installation.

Variable frequency drive:

- Will ALTERNATE the lead pump every 24 hours (field adjustable) of run time. The lag pump shall be in standby
- Shall have hands-off automatic (HOA) capability
- Rated to operate using specified power requirement. The drive efficiency shall be 98% or better
- Have UL approval with all factory installed options and preset values and/or last saved data values will remain available to the operator after power outage
- Shall have at least NEMA 1 rated conduit enclosure
- The program will protect the pumps against damaging hydraulic conditions such as:
 - Motor overload, Pump overflow surges, Loss of prime due to incoming water supply interruption, Hunting
 - Protection from overload through frequency/current optimization
 - Protection from hydraulic damage by restricting the pumps to operate beyond their published end of curve
- Shall have the ability to automatically restart after an over-current, over-voltage, under-voltage or loss of input signal
- Shall have an operator control panel [keypad] for customization of parameters
- Shall include a feature to upload/download parameters into an external device to be used with another drive or the same drive
- Shall have a removable non-volatile memory device
- Shall be capable of accepting individual analog inputs from transducer. All transducer inputs must be wired to the variable frequency drive for continuous scan and comparison function
- Ladder logic program shall utilize a proportional - integral - derivative control function
- Shall display the following values:
 - Pump running/standby, Pump speed in Hz, User adjustable parameters such as PID set points, Motor frequency, Motor current, Threshold set points for PID error, Min operating frequency, Troubleshooting and diagnostics of faults

Transducer:

- The transducer shall be rated for required system pressure and shall be 4-20 mA analog
- Separate transducers shall be supplied for each variable frequency drive to ensure redundancy

Centrifugal pump:

- Shall have a cast iron casing with 304 stainless steel impellers.
- Shall have a 316 stainless steel shaft sleeve. Mechanical seal shall be rated to withstand pressure of up to 232 PSI
- Motor shall be to totally enclosed fan cooled (TEFC). and manufactured in compliance with CE, RoHS and CSA

Pneumatic expansion tank:

- Pneumatic expansion tank shall be rated for use with potable water with an operating pressure of a maximum 150 PSI
- Pre-charged to a pressure of 10 PSI below system operating pressure for system to run properly

Manifolds, valves and fittings:

- Manifolds are designed for either right or left access
- Shall be sized appropriately to allow water velocity not exceeding 10 ft/sec, to minimize cavitation and turbulence
- Check valves shall be silent and spring-loaded

Installation:

- Equipment shall be installed in accordance with applicable local building, electrical and plumbing codes
- Shall be installed indoors (unless otherwise specified) and protected from water spray



Service Conditions:

Ambient Temperature: -10°C to 40°C (14°F to 104°F) NEMA 1,
Humidity: 95% RH, non-condensing
Altitude: 3300 ft; higher by derate
Input voltage: +10%/-15%
Input frequency: 50/60 Hz ± 5%
3-phase, 3-wire, phase sequence insensitive

Design Features:

LCD keypad display, 5 lines x 16 characters, backlit, 6 languages, copy function
Multi-step speed settings: 5 available
Setpoint (PI) control
32-bit microprocessor logic
Nonvolatile memory, program retention
Displacement power factor: 0.98
Output frequency: 0.1 to 120 Hz
Frequency resolution: 0.06 Hz
Frequency regulation: 0.1%
Control Terminal Board: Quick disconnect
Carrier frequency: selectable to 15 kHz
24 VDC control logic, PNP / NPN selectable
Transmitter/Option power supply
Input/output terminal status
Timer function: Elapsed time, Delay on start, Delay on stop
RS-422/485 port: Modbus protocol
Volts/hertz ratio: Preset and programmable V/Hz patterns
Meter Functions: Volt, amp, kilowatt, elapsed run time, speed command
NEMA 1 or protected chassis
UL, cUL listed and CE marked; IEC 146;
MTBF: exceeds 28 years

Pump Protective Features:

Dry Well
Air in System
Blocked Impeller
Pump over Cycling
No Flow Protection
Loss of Prime
Transducer Loss
Over Torque

Performance Features:

Overload capacity: nominal 110% for 60sec. (150% peak)
Starting torque: 100% at 3 Hz
Motor preheat function
Adjustable accel/decel: 0.1 to 6000 sec.
Critical frequency rejection: 3 selectable, adjustable bands
Torque-limiting: 30-180%
Energy Saving control
Torque boost: full range, auto
Power loss ride-thru: 2 sec
Auto restart after power loss or resettable fault, selectable, programmable
Feedback signal loss detection
Serial communications loss detection
"Up/Down" floating point control capability (PI)
Stationary motor auto-tuning
Pump Sleep function
Run-permissive input

PNEUMATIC EXPANSION TANK SPECIFICATIONS



WELL-X-TROL®

Diaphragm Well Tanks: WX-100, 200 and 300 Series

150 PSIG Working Pressure

Construction

Shell	High Strength Steel
Diaphragm	Heavy Duty Butyl
Liner	Antimicrobial
System Connection	Stainless Steel
Finish	Tuf-Kote™ HG Blue
Water Circulator	Turbulator™
Air Valve	Projection Welded
Factory Precharge	38 PSIG (2.6 bar)

Performance

Maximum Operating Temperature	200°F (93°C)
Maximum Working Pressure	150 PSIG (10.3 bar)
Maximum Relief Valve Setting	125 PSIG (8.6 bar)
Warranty	7 Year

Application

- Controls pump cycling in residential well water systems.
- Can be installed indoors or outdoors.

In-Line Models

Model Number	Tank Volume		Max. Acceptance Factor	A Tank Height		B Tank Diameter		System Connection (NPTM)	Shipping Weight	
	Gal	Lit		In	mm	In	mm		Lbs	Kg
WX-101	2.0	8	0.45	13	330	8	203	¾	5	2
WX-102	4.4	17	0.55	15	381	11	279	¾	9	4
WX-103	7.6	29	0.43	22	559	11	279	¾	15	7
WX-104	10.3	39	1.00	18	457	15	381	1	20	9
WX-200	14.0	53	0.81	22	559	15	381	1	22	10

Available in gray. Use suffix G.

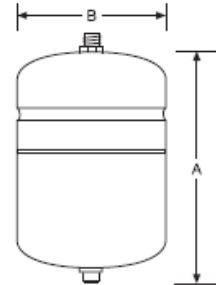

Stand Models

Model Number	Tank Volume		Max. Accept. Factor	A Tank Height		B Tank Diameter		C Sys. Conn. Centerline		D Stand Diameter		System Conn. (NPTM)	Shipping Weight	
	Gal	Lit		In	mm	In	mm	In	mm	In	mm		Lbs	Kg
WX-201	14.0	53	0.81	25	635	15	381	1 1/32	40	12	304	1	25	11
WX-202	20.0	76	0.57	32	813	15	381	1 1/32	40	12	304	1	33	15
WX-202XI	26.0	98	0.44	39	991	15	381	1 1/32	40	12	304	1	36	16
WX-203	32.0	121	0.35	47	1194	15	381	1 1/32	40	12	304	1	43	20
WX-205	34.0	129	1.00	30	762	22	559	1 1/16	49	20 1/2	521	1 1/4	61	28
WX-250	44.0	167	0.77	36	914	22	559	1 1/16	49	20 1/2	521	1 1/4	69	31
WX-251	62.0	235	0.55	47	1194	22	559	1 1/16	49	20 1/2	521	1 1/4	92	42
WX-255	81.0	306	0.41	57	1448	22	559	1 1/16	49	20 1/2	521	1 1/4	103	47
WX-252*	86.0	326	0.39	62	1575	22	559	1 1/16	49	20 1/2	521	1 1/4	114	52
WX-302	86.0	326	0.54	47	1194	26	660	2 1/16	52	20 1/2	521	1 1/4	123	56
WX-350	119.0	450	0.39	62	1575	26	660	2 1/16	52	20 1/2	521	1 1/4	166	75

*WX-252: Maximum Working Pressure: 100 PSIG. Available in Blue only. Available in Tan and Gray. Use suffix T or G.

All dimensions and weights are approximate.

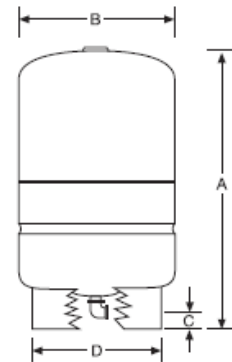



Booster Pump Systems

Three Year Limited Warranty

This warranty applies to booster pump systems built by Towle Whitney LLC, and shall:

- Exist 36 months from the date of shipment.
- Be in effect only after installation photographs are received by Towle Whitney LLC.

Towle Whitney LLC liability under this warranty shall be limited to the repair or replacement of any part or parts found to be defective (material or workmanship) within the warranty period. Towle Whitney LLC shall determine whether the part needs to be returned, or field scrapped. The warranty excludes:

- Any water damage or consequential damage.
- Transducers & Pump Seals.
- Debris in water causing damage to pump internal parts.
- Systems not installed in accordance with Installation and Maintenance Instructions.
- Labor, transportation, and related costs incurred by the customer.
- Misuse, negligence, inappropriate chemicals or additives in water.
- Inadequate protection from freezing.
- Lightning, high voltage spikes, accidents, floods, or acts of God.
- Re-Installation costs of repaired or replacement equipment.
- Re-Imbursement for the loss caused by interruption of service.
- Adjusting drive parameters without consulting Towle Whitney.

This warranty applies to all states and territories of the United States and Canada only. There are no express or implied warranties, including merchantability or fitness for a particular purpose, which extend beyond those warranties described or referred to above.

Some jurisdictions do not allow the exclusion or limitation of incidental or consequential damages and some jurisdictions do not allow limit actions on how long implied warranties may last. Therefore, the above limitations or exclusions may not apply. This warranty gives you specific legal rights and you may also have other rights which vary from jurisdiction to jurisdiction.